

2017

SI 

KATALOG

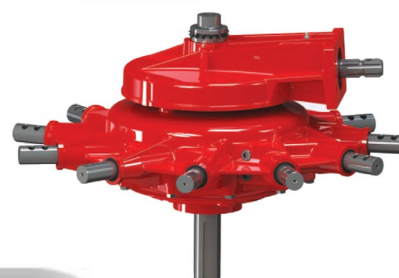

www.kptrgovina.si

HMEZAD KMETIJSKA PRESKRBA ŽALEC Šlandrov trg 19, 3310 Žalec, Slovenija

E-mail: trgovina.zalec@siol.net GSM: 041-232579 Tel: 03-5716758

NAVODILA ZA UPORABO IN
TEHNIČNI PODATKI



str.1-3

KARDANSKE GREDI



str.4-25

DELI



str.26-44

GREDI



str.44-45

ZAŠČITE IN DELI



str.46-51

ZAŠČITE PRIKLJUČNIH
GREDI NA STROJIH



str.52-57

GONILA



str.58-60

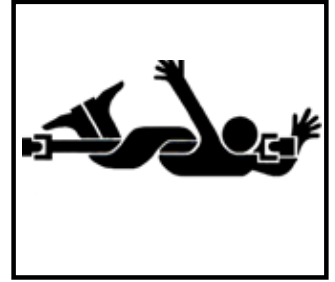
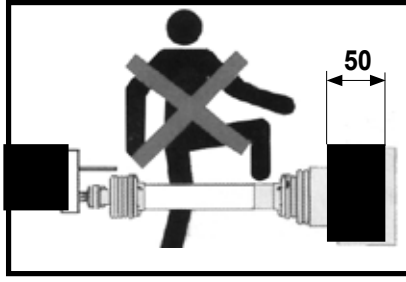

Bodite prepričani, da so zaščite, ki so montirane na stroju in traktorju dovolj dolge in pokrivajo vse rotirajoče dele v horizontalni in vertikalni poziciji. Preverite, da zaščita (na kardanu in stroju) pokriva vse rotirajoče dele, ko je kardan v maksimalnem delovnem kotu. Minimalno prekrivanje zaščite kadrana in zaščite stroja ali traktorja je 50 mm. **NEZADOSTNO PREKRIVANJE, LAHKO OGROZI VARNOST DELAVCA!** Bodite prepričani, da je kardan pravilno zmontiran in varovan. Pazite, da je kardan pravilno obrnjen. Znak traktorja, mora biti vedno montiran na traktorju. Montirajte verižice na traktor in stroj, da se zaščita ne bo vrtela. **NIKOLI NE DELAJTE BREZ ZAŠČIT ALI BREZ FIKSIRANIH VERIŽIC KARDANA!**

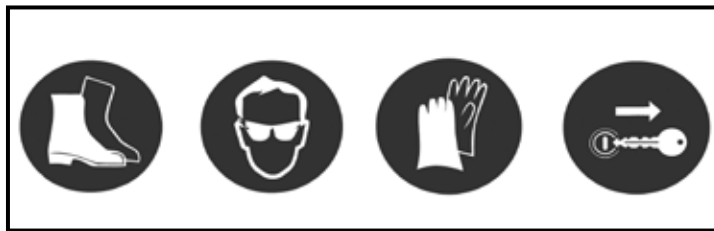

Oblecite primerno oprijeta oblačila. Uporabljajte rokavice, očala in delovne čevlje, ko rukujete s kardanom. Izberite vrsto gredi glede na moč navora priključka.

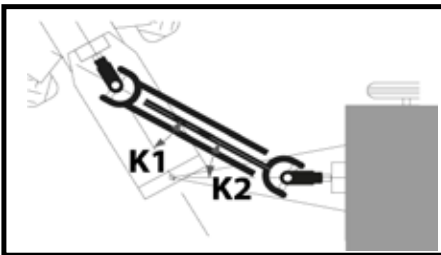

Delovni kot največ 25°. Prizadevati si za čim manjše in enake kote K1 in K2. Momentalna obremenitev, da pri tem niso preobremenjene zaščite je največ 45°. V mirovanju pa največ 90°.

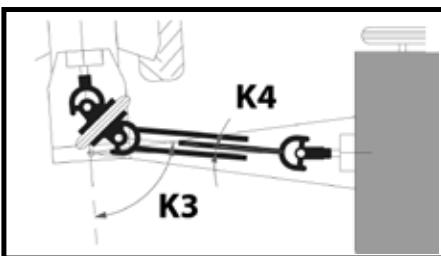



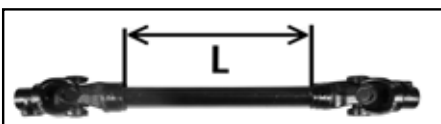

Momentalna obremenitev, da pri tem niso preobremenjene zaščite je od 50° do največ 75°. S tem je mišljena uporaba v zavojih. V mirovanju pa največ 90°. Pri uporabi 540 ali 1000 obratov je potrebno biti pozoren na vibracije, zato je priporočljiva konstantna uporaba pod čim manjšim kotom. Prizadevati si, da sta kota K3 in K4 pri konstantni uporabi čim manjša.

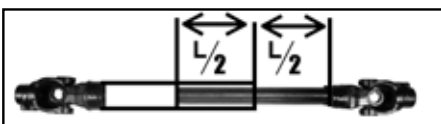

Kardan mora imeti vsaj polovico celotne dolžine ene cevi v drugi cevi, da je zagotovljeno optimalno delovanje. Prizadevajte si za največje prekritje cevi! Če niso upoštevana navodila o prekrivanju cevi lahko pride do zvitja cevi

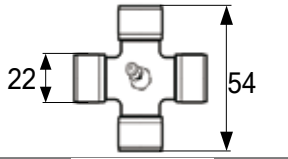
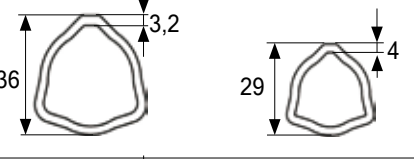

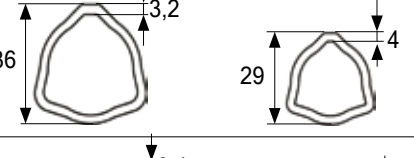
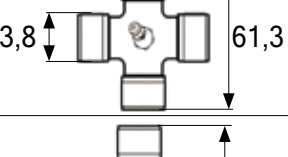
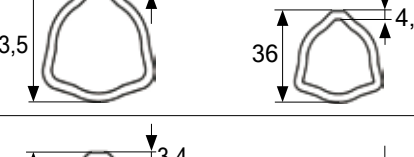
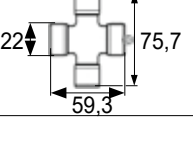
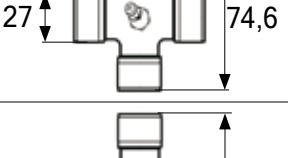
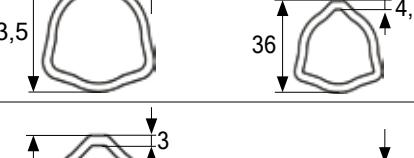
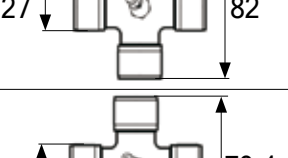
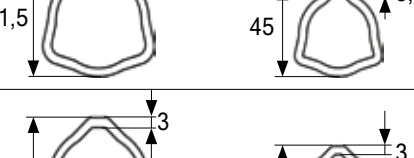
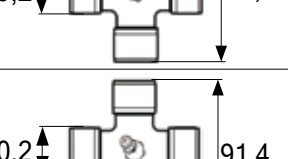
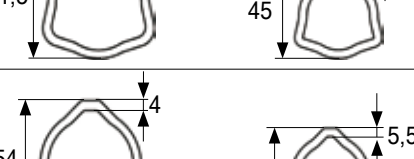
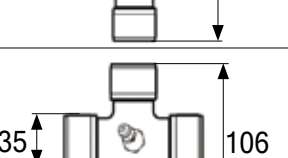
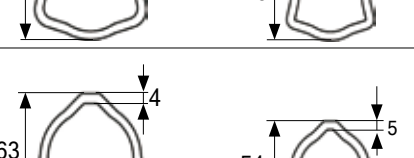
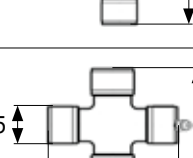
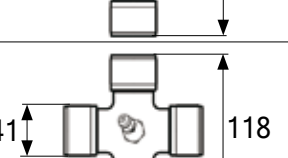
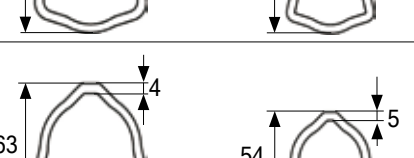
Kardansko gred transportirajte v vodoravnem položaju, ker se le ta lahko razstavi in poškoduje uporabnika.

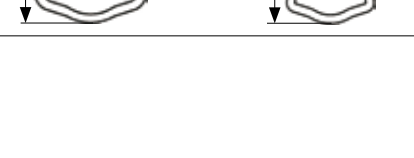
velikost	~primerjava B&P Walterscheid	križi enojnega zgloba mm	tip cevi mm	križi širokokotnega zgloba 80°, mm
T1	B&P A1 B&P G1 W100E	 22, 54	 36, 3,2, 29, 4	
T12	B&P A2 B&P G2 W200E	 23,8, 61,3	 36, 3,2, 29, 4	
T2	B&P A2 B&P G2 W200E	 23,8, 61,3	 43,5, 3,4, 36, 4,5	 23,7, 22, 75,7, 59,3
T3	B&P A4 B&P G4 W300E	 27, 74,6	 43,5, 3,4, 36, 4,5	
T4	B&P G4 W2300	 27, 82	 51,5, 3, 45, 3,8	
T45	B&P A5 B&P G5 W400E	 30,2, 79,4	 51,5, 3, 45, 3,8	
T5	B&P A6 B&P G7 W-P400	 30,2, 91,4	 54, 4, 45, 5,5	 30,2, 99,4
T7	B&P A8 W2500	 35, 106	 63, 4, 54, 5	 35, 106, 113,8
T8	B&P A10 W-P600	 41, 118	 63, 4, 54, 5	

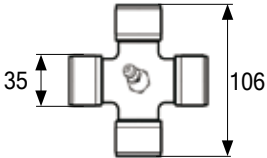
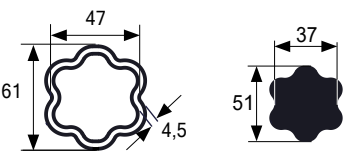
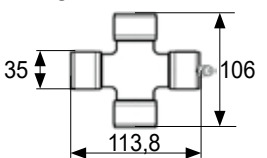
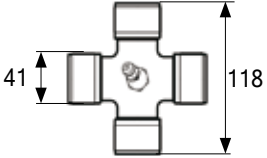
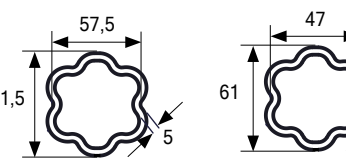
velikost	~primerjava B&P Walt.	križi enojnega zgloba mm	tip cevi mm	križi širokokotnega zgloba 80°, mm
X7	B&P S9 B&P A8 W-P500			
X8	B&P SH B&P A10 W-P600			

velikost	pri 540 min ⁻¹			pri 1000 min ⁻¹			maksimalni dinamični navor
	MOČ		NAVOR	MOČ		NAVOR	
	KW	KM	Nm	KW	KM	Nm	Nm
T1	12	16	210	18	25	172	320
T12	15	21	270	23	31	220	450
T2	19	25	350	30	40	300	600
T3	26	35	460	40	55	380	780
T4	30	41	540	47	64	450	9 50
T45	35	47	620	54	74	520	1050
T5	47	64	830	74	100	710	1450
T7	70	95	1240	110	150	1050	2250
T8	106	145	1890	170	230	1630	3800
X7	77	103	1300	116	155	1110	2310
X8	113	151	1950	177	237	1690	3870

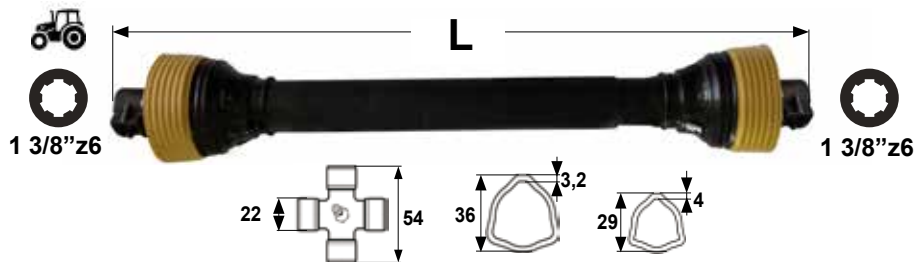
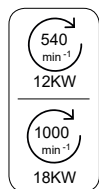

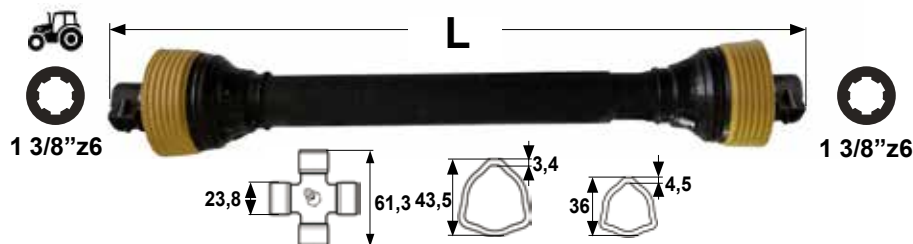
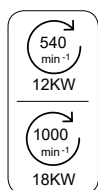

ŠIFRA ZA NAROČILO	VELIKOST	L mm	OPIS	UPORABA
203702	T1	700	Kardan direktni	Kardan celotne dolžine 700mm - splošna uporaba.
175604	T1	850	Kardan direktni	Obračalniki SIP Favorit 165, 185, enorotorski trosilec umetnih gnojil (Creina, Prodag, Tehnos, Ino, Ferti, Amazone, Rauch ...).
203703	T1	1000	Kardan direktni	Sejalnica pnevmatska dvoredna (Becker, Olt).
177820	T1	1100	Kardan direktni	Kardan celotne dolžine 1100mm - splošna uporaba.
203704	T1	1200	Kardan direktni	Kardan celotne dolžine 1200mm - splošna uporaba.
203705	T1	1500	Kardan direktni	Kardan celotne dolžine 1500mm - splošna uporaba.



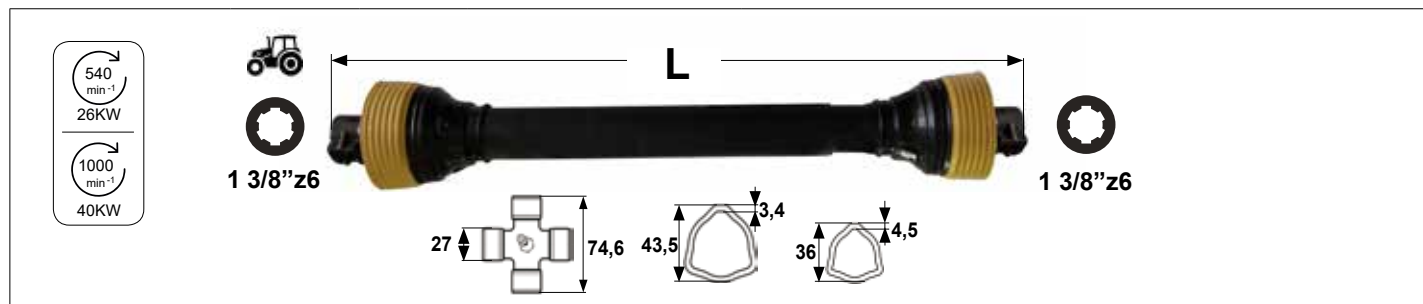

ŠIFRA ZA NAROČILO	VELIKOST	L mm	OPIS	UPORABA
203706	T2	700	Kardan direktni	Kardan celotne dolžine 700mm - splošna uporaba.
177737	T2	800	Kardan direktni	Obračalnik SIP Favorit 160, 180, 200, 220; v primeru, ko ima traktor kratke dvizžne roke.
870347	T2	860	Kardan direktni	Obračalnik SIP Favorit 200, 220, 240, 270; dvorotorski trosilec umetnih gnojil
203707	T2	1000	Kardan direktni	Kardan celotne dolžine 1000mm - splošna uporaba.
177738	T2	1100	Kardan direktni	Kardan celotne dolžine 1100mm - splošna uporaba.
203708	T2	1200	Kardan direktni	Kardan celotne dolžine 1200mm - splošna uporaba.
176407	T2	1400	Kardan direktni	Kardan celotne dolžine 1400mm - splošna uporaba.

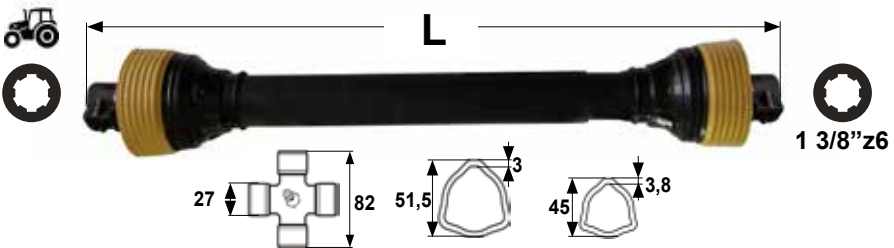

ŠIFRA ZA NAROČILO	VELIKOST	L mm	OPIS	UPORABA
203709	T3	700	Kardan direktni	Kardan celotne dolžine 700mm - splošna uporaba.
177739	T3	780	Kardan direktni	Vitel od 3 do 5 ton, cepilec hidravlični do 20 ton (Krpan, Tajfun, Uniforest).
177740	T3	890	Kardan direktni	Vitel od 3 do 5 ton (Krpan, Tajfun, Uniforest) - uporaba pri traktorjih, ki imajo daljše dvižne roke.
175613	T3	970	Kardan direktni	Cisterne do 5000l, Creina, atomizer, Mulčerji do 1,6m delovne širine, z že vgrajeno prostotekočo sklopko.
177741	T3	1100	Kardan direktni	Mešalec gnojevke Kirchner, cisterne do 5000l, Creina, Joskin, Vaia.
175614	T3	1220	Kardan direktni	Cisterne do 5000l, Creina, atomizer.
176408	T3	1500	Kardan direktni	Kardan celotne dolžine 1500mm - splošna uporaba.
203710	T3	1800	Kardan direktni	Kardan celotne dolžine 1800mm - splošna uporaba.

  					
	ŠIFRA ZA NAROČILO	VELIKOST	L mm	OPIS	UPORABA
	180402	T4	800	Kardan direktni	Vitel od 4 do 7 ton, cepilec hidravlični do 28 ton (Krapan, Tajfun, Uniforest).
	180403	T4	1000	Kardan direktni	Cisterne do 10000l.
180404	T4	1400	Kardan direktni	Kardan celotne dolžine 1400mm - splošna uporaba.	

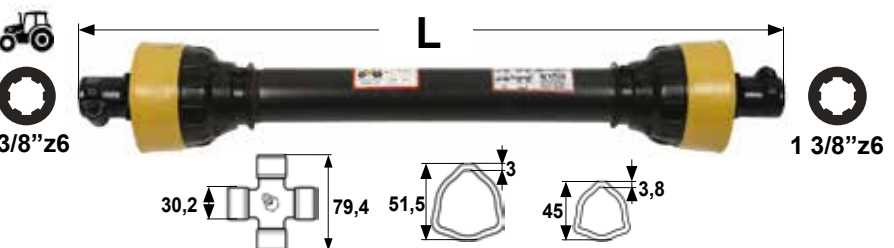
  					
	ŠIFRA ZA NAROČILO	VELIKOST	L mm	OPIS	UPORABA
	203711	T45	700	Kardan direktni	Vitel od 6 do 10 ton, cepilec hidravlični nad 28 ton (Krapan, Tajfun, Uniforest).
	180405	T45	800	Kardan direktni	Vitel od 6 do 10 ton, cepilec hidravlični nad 28 ton (Krapan, Tajfun, Uniforest).
180406	T45	1000	Kardan direktni	Cisterne do 14000l.	
203712	T45	1200	Kardan direktni	Kardan celotne dolžine 1200mm - splošna uporaba.	
180407	T45	1400	Kardan direktni	Kardan celotne dolžine 1400mm - splošna uporaba.	

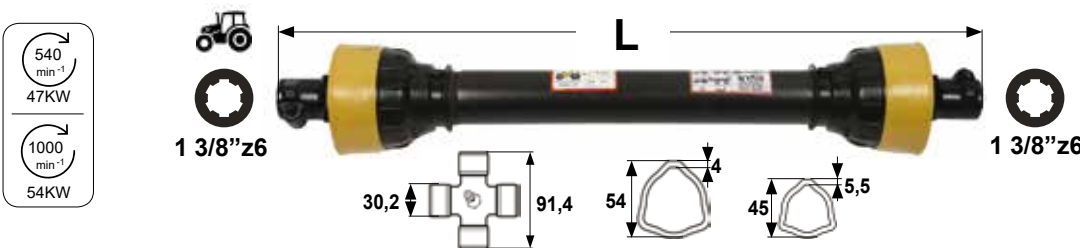





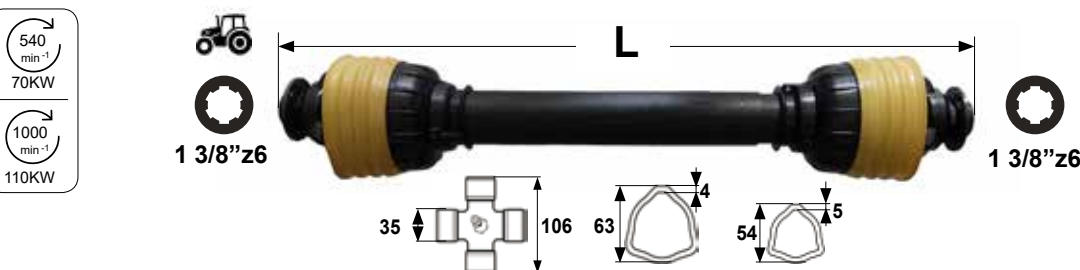

Technical drawing of a T5 direct shaft. The shaft is shown with a tractor icon at the top left. Dimensions include a total length 'L', a central section of 91,4 mm, and a distance of 30,2 mm from the end to the start of the central section. Cross-sections show a 54 mm diameter with a 4 mm offset and a 45 mm diameter with a 5,5 mm offset. Power specifications are 540 min⁻¹ / 47KW and 1000 min⁻¹ / 54KW. The shaft has a 1 3/8" z6 thread at both ends.





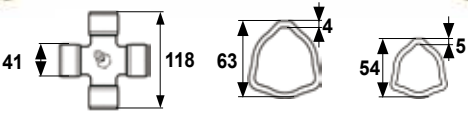

ŠIFRA ZA NAROČILO	VELIKOST	L mm	OPIS	UPORABA
203713	T5	700	Kardan direktni	Kardan celotne dolžine 70cm - splošna uporaba.
177742	T5	790	Kardan direktni	SIP SILO 40, SK40, SILO 80B, silažni kombajni.
177743	T5	890	Kardan direktni	Svedrasti cepilec drv, mešalec gnojevke.
175619	T5	990	Kardan direktni	Cisterne do 16000l (Creina, Kirchner, ...). Mulčerji od 1,8m do 2,4m delovne širine, z že vgrajeno prostotekočo sklopko.
177744	T5	1100	Kardan direktni	Mešalec gnojevke Kirchner, cisterne do 16000l, Creina.
203714	T5	1250	Kardan direktni	Kardan celotne dolžine 1250mm - splošna uporaba.
176409	T5	1500	Kardan direktni	Kardan celotne dolžine 1500mm - splošna uporaba.



Technical drawing of a T7 direct shaft. The shaft is shown with a tractor icon at the top left. Dimensions include a total length 'L', a central section of 106 mm, and a distance of 35 mm from the end to the start of the central section. Cross-sections show a 63 mm diameter with a 4 mm offset and a 54 mm diameter with a 5 mm offset. Power specifications are 540 min⁻¹ / 70KW and 1000 min⁻¹ / 110KW. The shaft has a 1 3/8" z6 thread at both ends.

ŠIFRA ZA NAROČILO	VELIKOST	L mm	OPIS	UPORABA
203715	T7	800	Kardan direktni	Kardan celotne dolžine 800mm - splošna uporaba.
177745	T7	900	Kardan direktni	Mulčer Tehnos MUL200LW, ostali mulčerji od 1,8 do 2m delovne širine. Prostotekoča sklopka mora biti vgrajena v stroju!
175620	T7	1010	Kardan direktni	Mulčer Tehnos MUL200LW, ostali mulčerji od 1,8 do 2m delovne širine. Prostotekoča sklopka mora biti vgrajena v stroju! Uporaba pri traktorjih, ki imajo daljše dvizžne roke.
177746	T7	1100	Kardan direktni	Mulčerji Tehnos MP 250, 280 LW, ostali mulčerji od 2,5 do 3m delovne širine. Prostotekoča sklopka mora biti vgrajena v stroju!
177062	T7	1300	Kardan direktni	Kardan celotne dolžine 1300mm - splošna uporaba.
203716	T7	1500	Kardan direktni	Kardan celotne dolžine 1500mm - splošna uporaba.

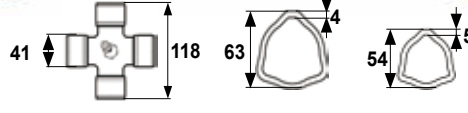
  1 3/8"z6	 L	 1 3/8"z6		 1 3/8"z6	 1 3/8"z6
ŠIFRA ZA NAROČILO	VELIKOST	L mm	OPIS	UPORABA	
182374	T8	1100	Kardan direktni	Težki mulčerji, rezalci sekancev, ki že imajo vgrajeno prostotekočo sklopko.	
203717	T8	1500	Kardan direktni	Težki mulčerji, rezalci sekancev, ki že imajo vgrajeno prostotekočo sklopko.	







  1 3/8"z6	 L	 1 3/4"z6		 1 3/8"z6	 1 3/4"z6
ŠIFRA ZA NAROČILO	VELIKOST	L mm	OPIS	UPORABA	
181629	T8	1000	Kardan direktni	Težki mulčerji, rezalci sekancev, ki že imajo vgrajeno prostotekočo sklopko, vrtavkaste brane, freze večjih širin. Kardan ima 1 3/4 z=6 na strani stroja.	





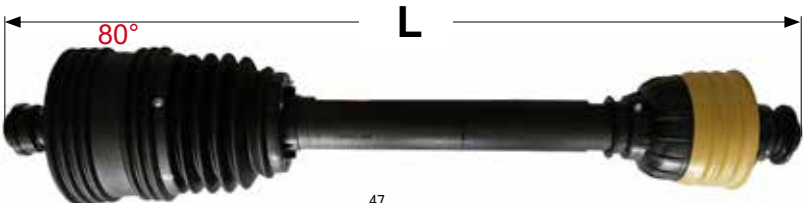

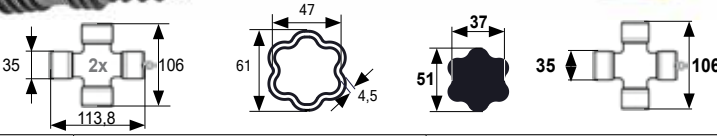
ŠIFRA ZA NAROČILO	VELIKOST	L mm	OPIS	UPORABA
203718	X7	800	Kardan direktni	Kardan celotne dolžine 800mm - splošna uporaba.
203719	X7	1100	Kardan direktni	Kardan celotne dolžine 1100mm - splošna uporaba.
203720	X7	1300	Kardan direktni	Kardan celotne dolžine 1300mm - splošna uporaba.





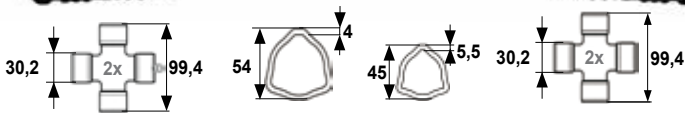

ŠIFRA ZA NAROČILO	VELIKOST	L mm	OPIS	UPORABA
203721	X8	800	Kardan direktni	Kardan celotne dolžine 800mm - splošna uporaba.
203722	X8	1100	Kardan direktni	Kardan celotne dolžine 1100mm - splošna uporaba.
203723	X8	1300	Kardan direktni	Kardan celotne dolžine 1300mm - splošna uporaba.

ŠIFRA ZA NAROČILO	VELIKOST	L mm	OPIS	UPORABA
203724	T2-T3	800	Kardan z zglobom širokokotnim 80°	Kardan celotne dolžine 800mm - splošna uporaba.
203725	T2-T3	1000	Kardan z zglobom širokokotnim 80°	Mešalec gnojevke Kirchner, cisterne za gnojevko do 16000l (Creina, Joskin, Vaia, Kirchner), škropilnica Myers.
203726	T2-T3	1200	Kardan z zglobom širokokotnim 80°	Kardan celotne dolžine 1200mm - splošna uporaba.
194993	T2-T3	1400	Kardan z zglobom širokokotnim 80°	Kardan celotne dolžine 1500mm - splošna uporaba.

ŠIFRA ZA NAROČILO	VELIKOST	L mm	OPIS	UPORABA
203728	T5	1100	Kardan z zglobom širokokotnim 80°	Mešalec gnojevke Kirchner, cisterne za gnojevko do 16000l (Creina, Joskin, Vaia, Kirchner), škropilnica Myers.
175625	T5	1250	Kardan z zglobom širokokotnim 80°	Mešalec gnojevke Kirchner, cisterne za gnojevko do 16000l (Creina, Joskin, Vaia, Kirchner), škropilnica Myers.
175872	T5	1450	Kardan z zglobom širokokotnim 80°	Balirke, ki že imajo vgrajeno prostotekočo in varnostno sklopko.

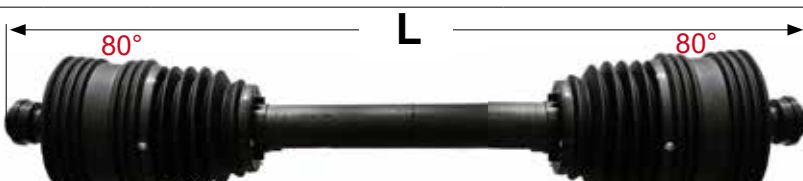
  1 3/8"z6			 1 3/8"z6		 
203729	X7	1200	Kardan z zglobom širokokotnim 80° direktni	Kardan celotne dolžine 1200mm - splošna uporaba.	
203730	X7	1500	Kardan z zglobom širokokotnim 80° direktni	Kardan celotne dolžine 1500mm - splošna uporaba.	

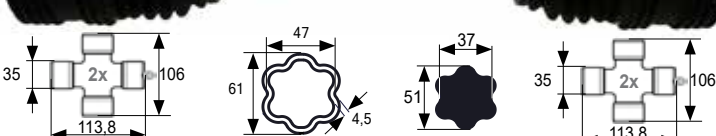
  1 3/8"z6			 1 3/8"z6		 
177777	T5	1100	Kardan z zglobom širokokotnim 80° na obeh straneh	Atomizer Myers (obračališče na sredini kardana.)	
177806	T5	1400	Kardan z zglobom širokokotnim 80° na obeh straneh	Atomizer Myers (obračališče na sredini kardana, daljši priklop.)	
177780	T5	1800	Kardan z zglobom širokokotnim 80° na obeh straneh	Stranski mulčer Tehnos MB170LW, MB200LW.	

  1 3/8"z6			 1 3/8"z6		 
203731	X7	1200	Kardan z zglobom širokokotnim 80° na obeh straneh	Kardan celotne dolžine 1200mm - splošna uporaba.	
203732	X7	1800	Kardan z zglobom širokokotnim 80° na obeh straneh	Kardan celotne dolžine 1800mm - splošna uporaba.	

ŠIFRA ZA NAROČILO	VELIKOST	L mm	OPIS	UPORABA
203733	T2	1000	Kardan s sklopko prostotekočo DESNI PROSTI TEK	Manjši kosilniki in mulčerji
203734	T2	1000	Kardan s sklopko prostotekočo LEVI PROSTI TEK	Manjši frontni kosilniki in mulčerji

ŠIFRA ZA NAROČILO	VELIKOST	L mm	OPIS	UPORABA
174790	T3	970	Kardan s sklopko prostotekočo DESNI PROSTI TEK	Kosilniki bobnasti SIP RK 135, ROTO135, DK165, ROTO170D, ROTO175D. Mulčerji do 1,5m Ino, Tehnos, Müthing, ki nimajo vgrajene prostotekoče sklopke.
175617	T3	970	Kardan s sklopko prostotekočo LEVI PROSTI TEK	Frontni mulčerji do 1,6m Ino, Tehnos, Müthing.
203735	T3	1250	Kardan s sklopko prostotekočo DESNI PROSTI TEK	Kosilniki diskasti Krone, SIP Poettinger do 1,8m

ŠIFRA ZA NAROČILO	VELIKOST	L mm	OPIS	UPORABA
178615	T3	970	Kardan s sklopko prostotekočo in prilagodljivo zaščito DESNI PROSTI TEK	Bobnasti kosilniki, SIP ROTO135, ROTO165, PÖTTINGER ECONOMY 170, diskasti kosilniki od 1,3 do 1,7m delovne širine.





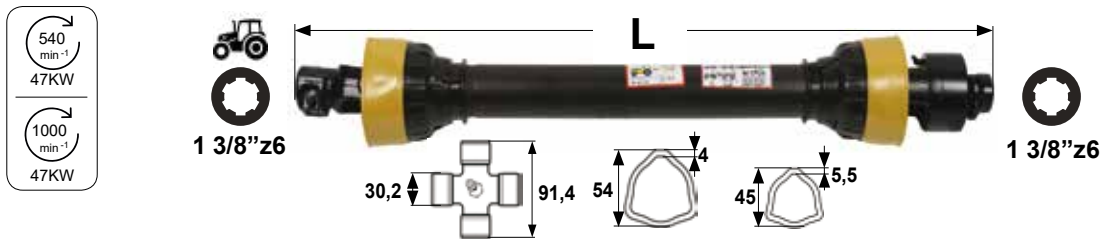

ŠIFRA ZA NAROČILO	VELIKOST	L mm	OPIS	UPORABA
180409	T4	970	Kardan s sklopko prostotekočo DESNI PROSTI TEK	Kosilniki bobnasti SIP RK 165, ROTO165, ROTO165G, ROTO185G, PÖTTINGER ECONOMY 170, PÖTTINGER ECONOMY 190, TECOSTAR T-TCMB 190.





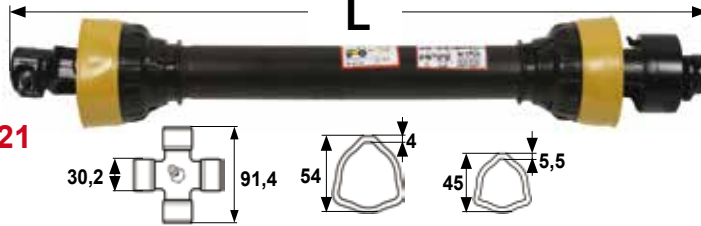

ŠIFRA ZA NAROČILO	VELIKOST	L mm	OPIS	UPORABA
181610	T4	970	Kardan s sklopko prostotekočo in prilagodljivo zaščito DESNI PROSTI TEK	Kosilniki bobnasti SIP RK 165, ROTO165, ROTO165G, ROTO185G, PÖTTINGER ECONOMY 170, PÖTTINGER ECONOMY 190, TECOSTAR T-TCMB 190.



ŠIFRA ZA NAROČILO	VELIKOST	L mm	OPIS	UPORABA
203736	T45	1000	Kardan s sklopko prostotekočo DESNI PROSTI TEK	Kosilniki bobnasti SIP ROTO210, ROTO220. Mulčerji do 1,6m do 2,2m, Ino, Tehnos, Müthing.
203737	T45	1000	Kardan s sklopko prostotekočo LEVI PROSTI TEK	Frontni kosilniki bobnasti do 2,2m. Mulčerji do 1,6m do 2m.
203738	T45	1300	Kardan s sklopko prostotekočo DESNI PROSTI TEK	Kosilniki bobnasti. Mulčerji do 1,6m do 2,2m.
203739	T45	1300	Kardan s sklopko prostotekočo LEVI PROSTI TEK	Frontni kosilniki bobnasti do 2,2m. Mulčerji do 1,6m do 2m.

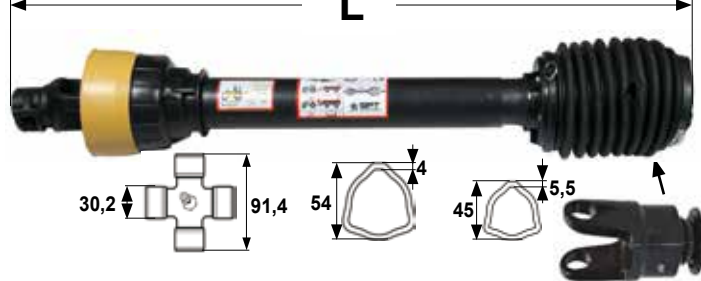





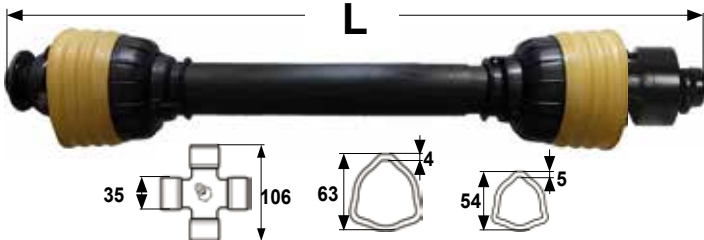



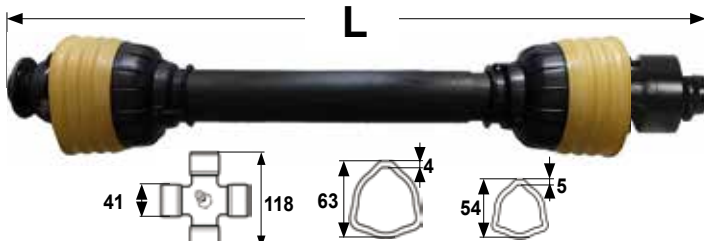

ŠIFRA ZA NAROČILO	VELIKOST	L mm	OPIS	UPORABA
870543	T5	890	Kardan s sklopko prostotekočo DESNI PROSTI TEK	Kombajn silažni enoredni SIP SK80, SILO80, SILO90, Mlin CIKLO100.
871362	T5	990	Kardan s sklopko prostotekočo DESNI PROSTI TEK	Kosilniki bobnasti SIP ROTO210, ROTO220, ROTO260. Mulčerji do 1,8m do 2,4m, Ino, Tehnos, Müthing.
175622	T5	990	Kardan s sklopko prostotekočo LEVI PROSTI TEK	Frontni kosilniki SIP ROTO220F, ROTO280F, ROTO285F, ROTO300F, ROTO311F. Frontni mulčerji od 1,8m do 2,4m, Ino, Tehnos, Müthing.
203631	T5	1150	Kardan s sklopko prostotekočo LEVI PROSTI TEK	Frontni kosilniki od 2,2 do 3m delovne širine. Frontni mulčerji od 1,8m do 2,4m, Ino, Tehnos, Müthing.
203740	T5	1300	Kardan s sklopko prostotekočo DESNI PROSTI TEK	Mulčerji do širine 2,2m, kosilniki bobnasti do širine 2,8m in diskasti kosilniki do širine 3m.
203741	T5	1300	Kardan s sklopko prostotekočo LEVI PROSTI TEK	Frontni mulčerji do širine 2,2m, frontni kosilniki bobnasti do širine 2,8m in frontni diskasti kosilniki do širine 3m.





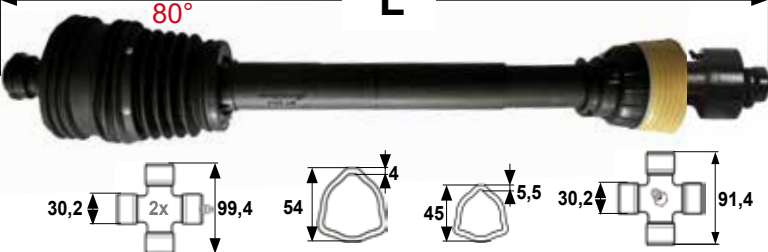

  1 3/8"z21		 1 3/8"z6		
				
ŠIFRA ZA NAROČILO	VELIKOST	L mm	OPIS	UPORABA
177142	T5	1000	Kardan s sklopko prostotekočo DESNI PROSTI TEK	Frontni kosilniki za traktorje ZETOR: SIP ROTO251F, ROTO275F, ROTO281F, ROTO311F; ISO VRTLJAJI ZETOR; Vilica na strani traktorja 1 3/8" z=21.





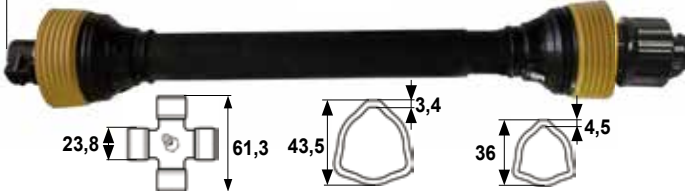
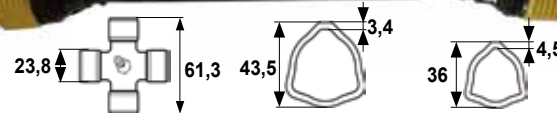

  1 3/8"z6		 1 3/8"z6		
				
ŠIFRA ZA NAROČILO	VELIKOST	L mm	OPIS	UPORABA
178616	T5	1000	Kardan s sklopko prostotekočo in prilagodljivo zaščito DESNI PROSTI TEK	Bobnasti kosilniki, SIP ROTO185, ROTO185G, ROTO220, ROTO220G, PÖTTINGER ECONOMY 190, diskasti kosilniki od 2,1 do 3m delovne širine.





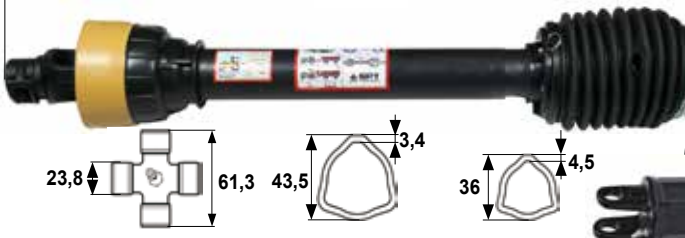

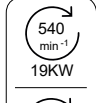
  1 3/8"z6	 1 3/8"z6		 	ŠIFRA ZA NAROČILO	VELIKOST	L mm	OPIS	UPORABA
				177799	T7	1200	Kardan s sklopko prostotekočo DESNI PROSTI TEK	Kosilniki stranski SIP ROTO od 2,6 do 3m, ki imajo montiran gnetilnik. Mulčerji do 2,4m do 3m, Ino, Tehnos, Mühthing.
177800	T7	1300	Kardan s sklopko prostotekočo LEVI PROSTI TEK	Kosilniki frontni SIP ROTO od 2,6 do 3m, ki imajo montiran gnetilnik. Frontni mulčerji od 2,4m do 3m, Ino, Tehnos, Mühthing.				

  1 3/8"z6	 1 3/4"z6		 	ŠIFRA ZA NAROČILO	VELIKOST	L mm	OPIS	UPORABA
				186599	T8	1800	Kardan s sklopko prostotekočo DESNI PROSTI TEK	Kardan celotne dolžine 1800mm - splošna uporaba.

  1 3/8"z6	 1 3/8"z6		 	ŠIFRA ZA NAROČILO	VELIKOST	L mm	OPIS	UPORABA
				175876	T5	1500	Kardan z zglobom širokokotnim 80° DESNI PROSTI TEK	Balirke, ki imajo vgrajeno varnostno sklopko, nimajo pa prostotekoče sklopke. Stroji z večjo silo vztrajnosti in z že vgrajenim preobremenitvenim varovanjem.

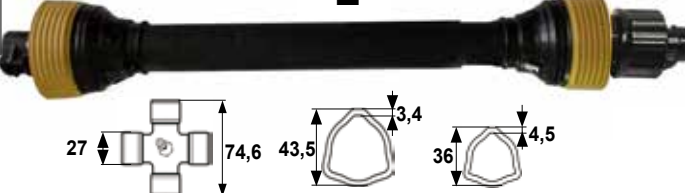
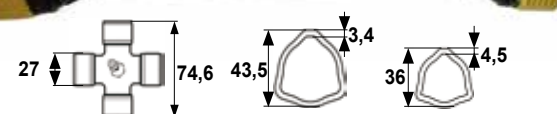
  1 3/8"z6	  	 1 3/8"z6	 	ŠIFRA ZA NAROČILO VELIKOST L mm OPIS UPORABA
			870773 T2 1060 Kardan s sklopko zvezdasto 500Nm Obračalnik vrtavkasti SIP SPIDER 350.	870342 T2 1210 Kardan s sklopko zvezdasto 600Nm Zgrabljalnik SIP STAR: 300, 330, 360, 380, 410, 470, SIP SPIDER 230, SIP SPIDER 400, SIP ORION 25.

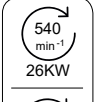
  1 3/8"z6	  	 1 3/8"z6	 	ŠIFRA ZA NAROČILO VELIKOST L mm OPIS UPORABA
			178679 T2 1050 Kardan s sklopko zvezdasto 600Nm in prilagodljivo zaščito Zgrabljalniki SIP STAR Modular 360/10, 400/11, 430/12, 470/13.	178614 T2 1260 Kardan s sklopko zvezdasto 600Nm in prilagodljivo zaščito Zgrabljalniki SIP STAR 300 do 470, SIP SPIDER 230, 300, SIP ORION 25R.

  1 3/8"z6	  	 1 3/8"z6	 	ŠIFRA ZA NAROČILO VELIKOST L mm OPIS UPORABA
			175611 T3 1140 Kardan s sklopko zvezdasto 600Nm Trosilci gnoja do 4 tone (Kirchner, Tehnostroj; SIP ORION 40, SRO230, SRO450, Prikolica SIP PIONIR 17, 20, 26.	175612 T3 1220 Kardan s sklopko zvezdasto 900Nm Trosilci gnoja do 5 ton, Prikolica samonakladalna SIP SENATOR MASTER: 22/9.

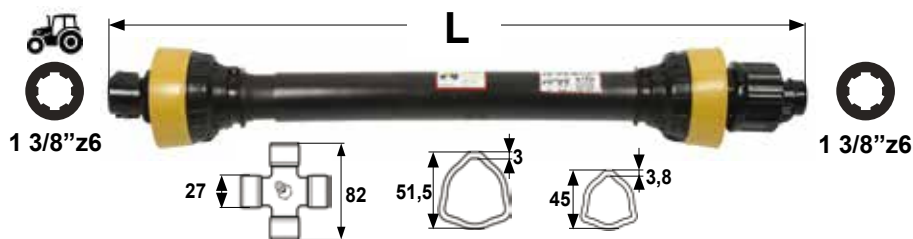
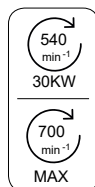

ŠIFRA ZA NAROČILO	VELIKOST	L mm	OPIS	UPORABA
180413	T4	1300	Kardan s sklopko zvezdasto 900Nm	Trosilci gnoja do 6 ton, SIP ORION 60, Prikolica samonakladalna SIP SENATOR MASTER: 26/9, 28/9.
180485	T4	1600	Kardan s sklopko zvezdasto 1000Nm	Obračalniki vrtavkasti od 5,5 do 6,5m: SIP SPIDER PRO 615.
182459	T4	1600	Kardan s sklopko zvezdasto 1200Nm	Obračalniki vrtavkasti od 6,5 do 9,0m: SIP SPIDER PRO 685, 815.

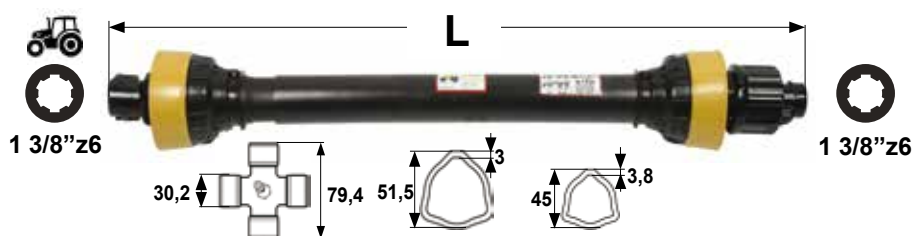
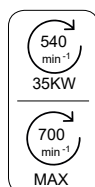

ŠIFRA ZA NAROČILO	VELIKOST	L mm	OPIS	UPORABA
203743	T45	1300	Kardan s sklopko zvezdasto 1500Nm	Trosilci gnoja, prikolice samonakladalne
203744	T45	1600	Kardan s sklopko zvezdasto 1500Nm	Trosilci gnoja, prikolice samonakladalne

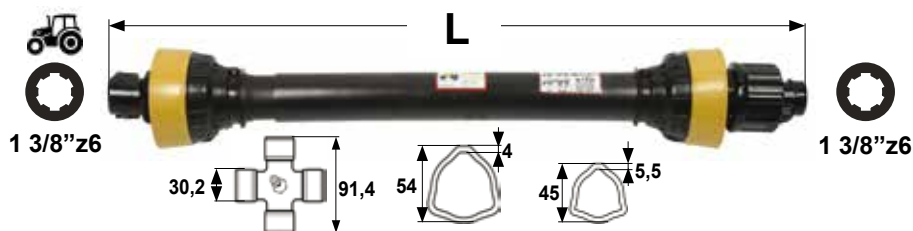
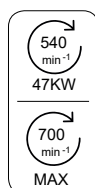

ŠIFRA ZA NAROČILO	VELIKOST	L mm	OPIS	UPORABA
203745	T5	1600	Kardan s sklopko zvezdasto 1500Nm	Trosilci gnoja, prikolice samonakladalne, obračalniki vrtavkasti.

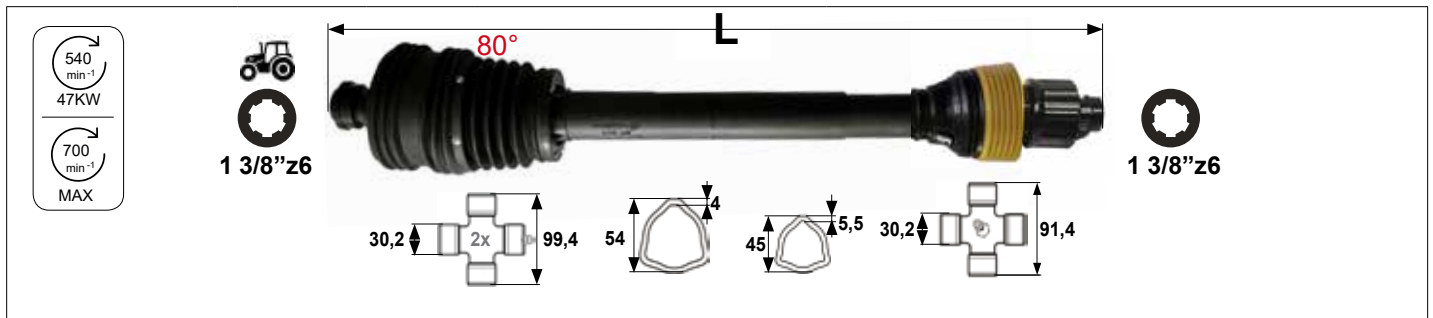

ŠIFRA ZA NAROČILO	VELIKOST	L mm	OPIS	UPORABA
175626	T5	1250	Kardan z zglobom širokokotnim 80° in SKLOPKO ZVEZDASTO 600Nm	Obiralec koruze SIP TORNADO 40, Prikolica SIP PIONIR 17, 22, 26.
176232	T5	1250	Kardan z zglobom širokokotnim 80° in SKLOPKO ZVEZDASTO 900Nm	Trosilec gnoja do 6 ton, SIP ORION 60, Prikolica SIP SENATOR MASTER 22/9, 26/9, 28/9.
175628	T5	1350	Kardan z zglobom širokokotnim 80° in SKLOPKO ZVEZDASTO 1200Nm	Trosilci gnoja, prikolice samonakladalne
203746	T5	1400	Kardan z zglobom širokokotnim 80° in SKLOPKO ZVEZDASTO 1500Nm	Trosilci gnoja, prikolice samonakladalne

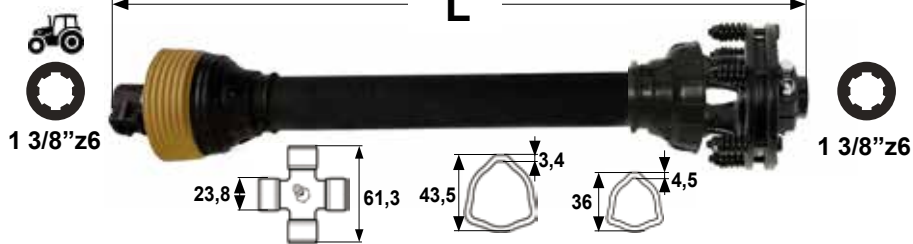
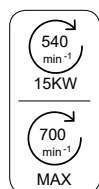

ŠIFRA ZA NAROČILO	VELIKOST	L mm	OPIS	UPORABA
181614	T2	900	Kardan s sklopko lamelno DVE LAMELI 400Nm	Vrtavkaste brane, freze od 0,6 do 1,2m delovne širine.

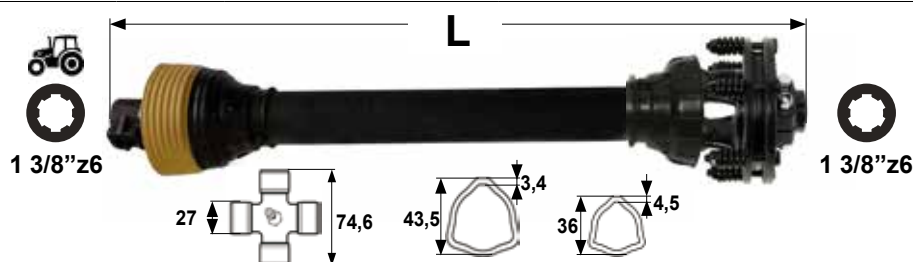
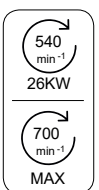

ŠIFRA ZA NAROČILO	VELIKOST	L mm	OPIS	UPORABA
177781	T3	900	Kardan s sklopko lamelno DVE LAMELI 750Nm	Vrtavkaste brane, freze od 0,8 do 1,4m delovne širine.
177782	T3	900	Kardan s sklopko lamelno DVE LAMELI 900Nm	Vrtavkaste brane, freze od 1,5 do 1,8m delovne širine.

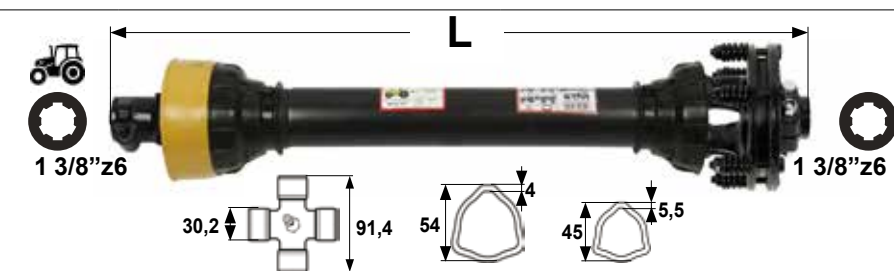
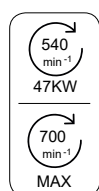











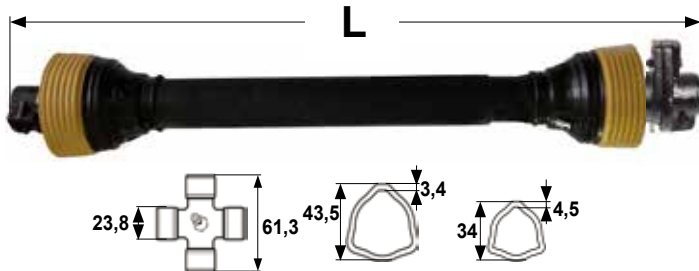

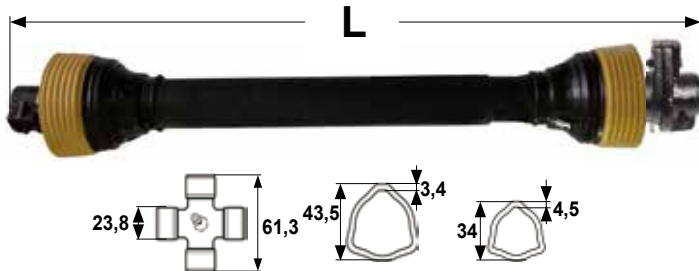
ŠIFRA ZA NAROČILO	K kategorija	L mm	OPIS	UPORABA
177784	T5	950	Kardan s sklopko lamelno DVE LAMELI 1200Nm	Vrtavkaste brane, freze od 1,8 do 2,2m delovne širine.





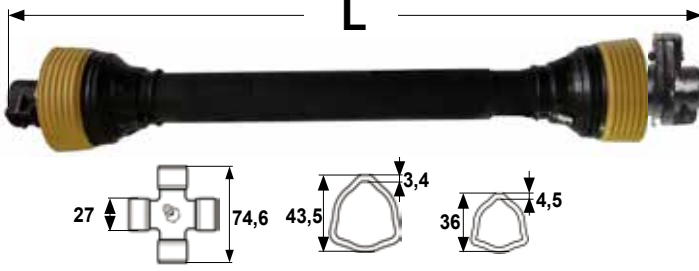

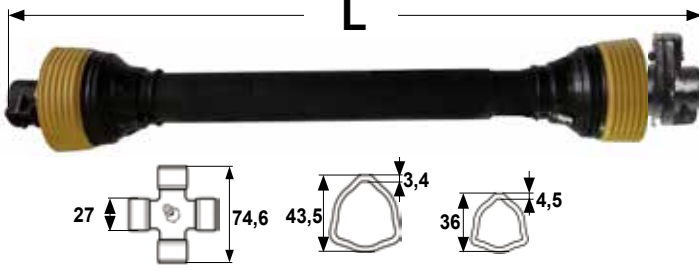
ŠIFRA ZA NAROČILO	VELIKOST	L mm	OPIS	UPORABA
177785	T7	1050	Kardan s sklopko lamelno DVE LAMELI 1200Nm	Vrtavkaste brane, freze od 1,8 do 2,2m delovne širine. UTORI NA SKLOPKI 1 ³ / ₄ z=6.
177786	T7	1050	Kardan s sklopko lamelno ŠTIRI LAMELE 1700Nm	Vrtavkaste brane, freze od 2,5 do 3m delovne širine



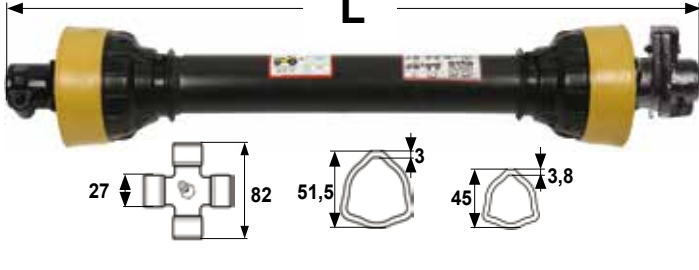

ŠIFRA ZA NAROČILO	VELIKOST	L mm	OPIS	UPORABA
177672	T7	900	Kardan s sklopko lamelno ŠTIRI LAMELE 1700Nm	Vrtavkaste brane, freze od 2,5 do 3m delovne širine. UTORI NA SKLOPKI 1 ³ / ₄ z=6.

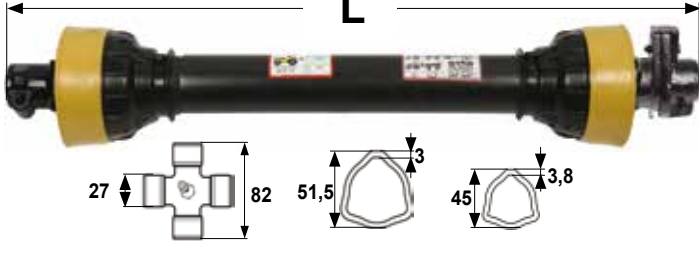



ŠIFRA ZA NAROČILO	VELIKOST	L mm	OPIS	UPORABA
181618	T5	1250	Kardan z zglobom širokokotnim 80° DVE LAMELI 1200Nm	Trosilci hlevskega gnoja od 8 do 10ton (SIP, Tehnos-troj), samonakladalne silažne prikolice do 24 nožev.



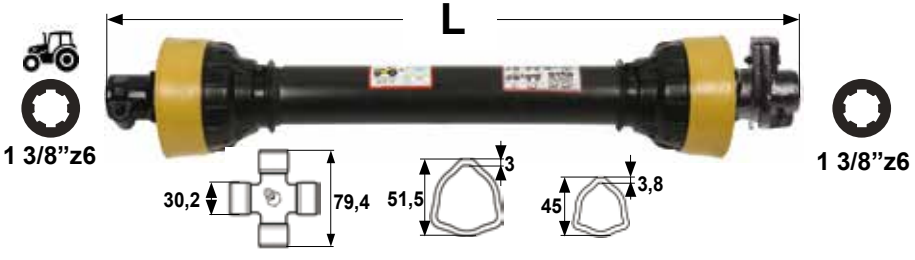

  1 3/8"z6		 1 3/8"z6		
			 	
ŠIFRA ZA NAROČILO	VELIKOST	L mm	OPIS	UPORABA
870700	T2	900	Kardan s sklopko strižno 900Nm	Pogon gnetilnika pri kosilnikih SIP ROTO 165G, 175DG, 185G.
176425	T2	1200	Kardan s sklopko strižno 900Nm	Pogon gnetilnika pri kosilnikih SIP ROTO 175DG, 215DG.



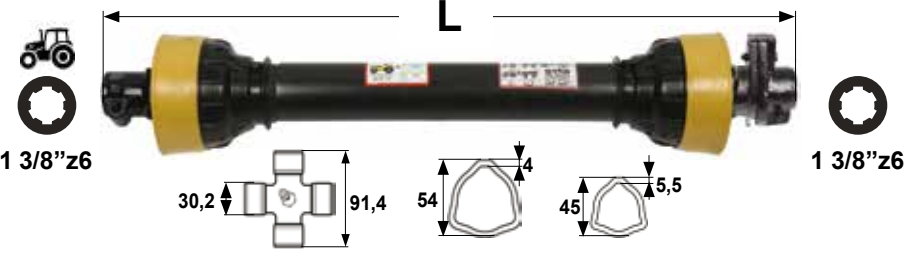



  1 3/8"z6		 1 3/8"z6		
			 	
ŠIFRA ZA NAROČILO	VELIKOST	L mm	OPIS	UPORABA
203747	T3	800	Kardan s sklopko strižno 1700Nm	Vinogradniške freze, mini freze od 1,2 do 1,6m.
176423	T3	1000	Kardan s sklopko strižno 1700Nm	Vinogradniške freze, mini freze od 1,2 do 1,6m.
870994	T3	1200	Kardan s sklopko strižno 1300Nm	Pogon gnetilnika pri kosilnikih SIP ROTO 220G, 220DG.

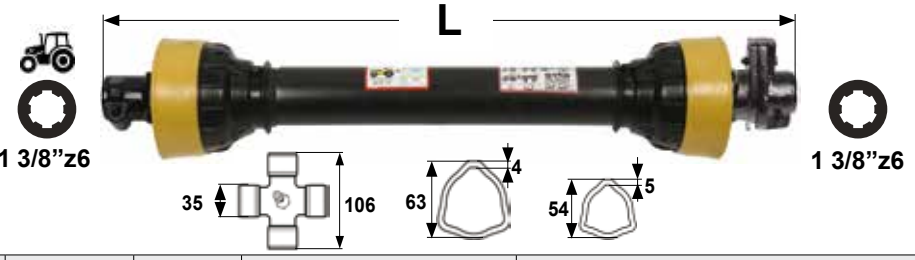



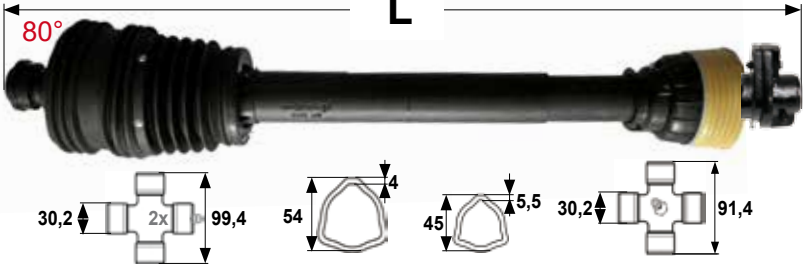

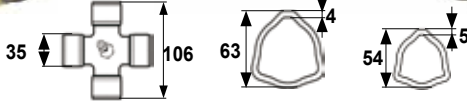
  1 3/8"z6		 1 3/8"z6		
			 	
ŠIFRA ZA NAROČILO	VELIKOST	L mm	OPIS	UPORABA
180443	T4	1500	Kardan s sklopko strižno 1900Nm	Sveder traktorski.





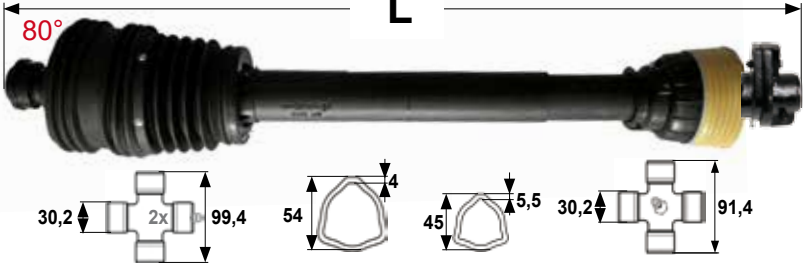

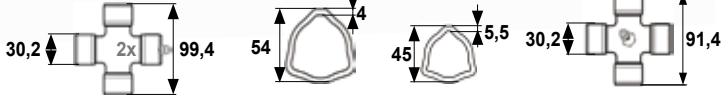
   					
	ŠIFRA ZA NAROČILO	VELIKOST	L mm	OPIS	UPORABA
	203748	T45	800	Kardan s sklopko strižno 2200Nm	Freze vinogradniške 1,6m do 2m
	203749	T45	1000	Kardan s sklopko strižno 2200Nm	Freze vinogradniške 1,6m do 2m
203750	T45	1200	Kardan s sklopko strižno 2200Nm	Kardan splošna uporaba	

   					
	ŠIFRA ZA NAROČILO	VELIKOST	L mm	OPIS	UPORABA
	175874	T5	950	Kardan s sklopko strižno 2500Nm	Vrtavkaste brane, freze od 2,2 do 2,8m.
	184718	T5	1550	Kardan s sklopko strižno 2500Nm	Kardan splošna uporaba

   					
	ŠIFRA ZA NAROČILO	VELIKOST	L mm	OPIS	UPORABA
	176424	T7	1000	Kardan s sklopko strižno 3500Nm	Vrtavkaste brane, freze 3m.

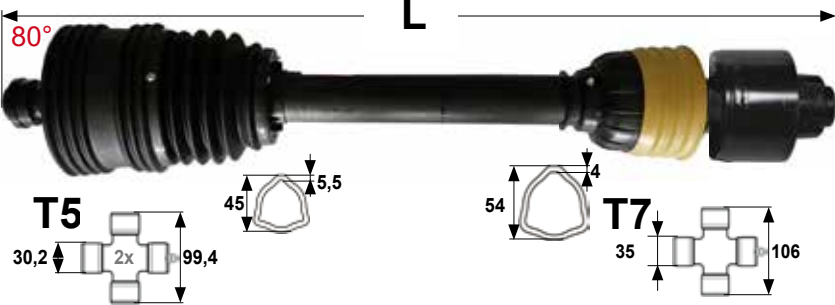
  1 3/8"z6	 L	 1 3/4"z6	 35 106 63 54 5	 540 min ⁻¹ 70KW	 700 min ⁻¹ MAX
177857	T7	1000	Kardan s sklopko strižno 3500Nm	Vrtavkaste brane, freze 3m. SKLOPKA 1 3/4 z=6.	

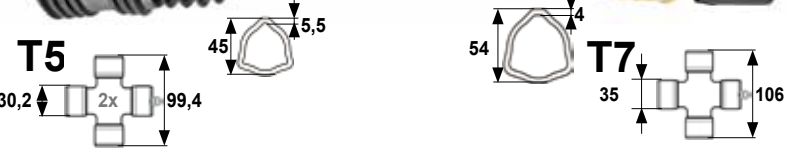
  1 3/8"z6	 L	 1 3/8"z6	 80° 30,2 2x 99,4 54 45 5,5 30,2 91,4	 540 min ⁻¹ 47KW	 700 min ⁻¹ MAX
182898	T5	1250	Kardan z zglobom širokokotnim 80° in SKLOPKO STRIŽNO 2500Nm	Balirke za okrogle bale, KRONE classic line tip KR 125, KR 130, KR 160.	
184717	T5	1500	Kardan z zglobom širokokotnim 80° in SKLOPKO STRIŽNO 2500Nm	Balirke za okrogle bale.	

  1 3/8"z6	 L	 1 3/8"z6	 80° T5 45 5,5 54 T7 35 106 30,2 2x 99,4	 540 min ⁻¹ 47KW	 700 min ⁻¹ MAX
177783	T5-T7	1400	Kardan s sklopko avtomatsko 1650Nm	Trosilniki organskih gnojil SIP, Orion 80, 120,130 in podobni	
179088	T5-T7	1400	Kardan s sklopko avtomatsko 1850Nm	Nakladalno silažne prikolice do 24 nožev	

					<table border="1"> <thead> <tr> <th>ŠIFRA ZA NAROČILO</th> <th>VELIKOST</th> <th>L mm</th> <th>OPIS</th> <th>UPORABA</th> </tr> </thead> <tbody> <tr> <td>179091</td> <td>X7</td> <td>1000</td> <td>Kardan s sklopko avtomatsko 2650Nm</td> <td>Vrtavkaste brane, freze delovne širine od 3 do 3,2m</td> </tr> </tbody> </table>	ŠIFRA ZA NAROČILO	VELIKOST	L mm	OPIS	UPORABA
ŠIFRA ZA NAROČILO	VELIKOST	L mm	OPIS	UPORABA						
179091	X7	1000	Kardan s sklopko avtomatsko 2650Nm	Vrtavkaste brane, freze delovne širine od 3 do 3,2m						

<h3>KARDAN Z VERIŽNIKOM ZA SILAŽNI KOMBAJN SIP SK40, SILO80B</h3>														
				<table border="1"> <thead> <tr> <th>ŠIFRA ZA NAROČILO</th> <th>KATALOŠKA OZNAKA</th> <th>SIP IDENT</th> <th>L mm</th> <th>UPORABA</th> </tr> </thead> <tbody> <tr> <td>875345</td> <td>KT5.Z42.3F2.090</td> <td>152498103</td> <td>900</td> <td>SIP SK 40, SILO 80B; kardan je vgrajen med rotorjem in glavnim gonilom.</td> </tr> </tbody> </table>	ŠIFRA ZA NAROČILO	KATALOŠKA OZNAKA	SIP IDENT	L mm	UPORABA	875345	KT5.Z42.3F2.090	152498103	900	SIP SK 40, SILO 80B; kardan je vgrajen med rotorjem in glavnim gonilom.
					ŠIFRA ZA NAROČILO	KATALOŠKA OZNAKA	SIP IDENT	L mm	UPORABA					
875345	KT5.Z42.3F2.090	152498103	900	SIP SK 40, SILO 80B; kardan je vgrajen med rotorjem in glavnim gonilom.										

ŠIFRA ZA NAROČILO	VELIKOST	L mm	B mm	OPIS
210633	T2	84	43,5	zglob širokokotni za zunanjo cev
210636	T2	84	36	zglob širokokotni za notranjo cev

ŠIFRA ZA NAROČILO	VELIKOST	L mm	B mm	OPIS
210637	T5	112	54	zglob širokokotni za zunanjo cev
210638	T5	112	45	zglob širokokotni za notranjo cev

ŠIFRA ZA NAROČILO	VELIKOST	L mm	B mm	OPIS
210641	T7	120	63	zglob širokokotni za zunanjo cev
210642	T7	120	54	zglob širokokotni za notranjo cev

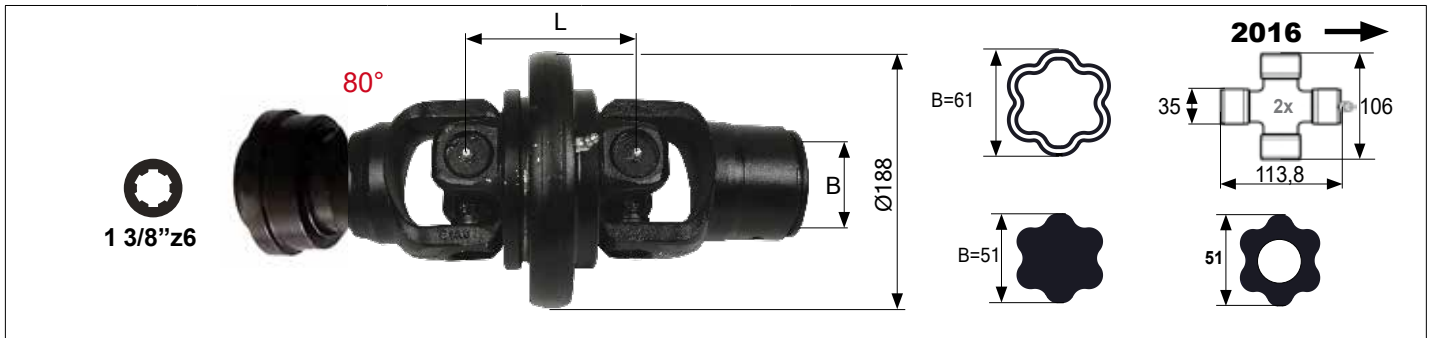

ŠIFRA ZA NAROČILO	VELIKOST	L mm	B mm	OPIS
210639	X7	120	61	zglob širokokotni za zunanjo cev
210640	X7	120	51	zglob širokokotni za cev ali palico notranjo

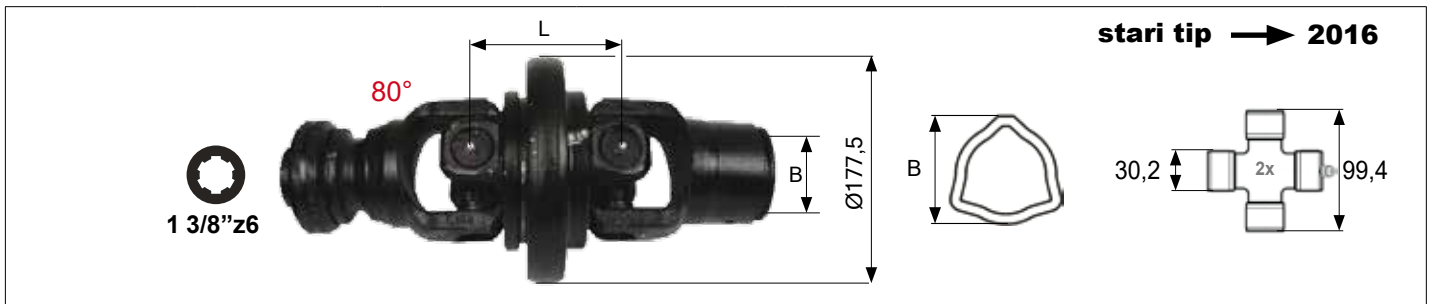

ŠIFRA ZA NAROČILO	VELIKOST	L mm	B mm	OPIS
175781	T5	112	54	zglob širokokotni za zunanjo cev
178617	T5	112	45	zglob širokokotni za notranjo cev

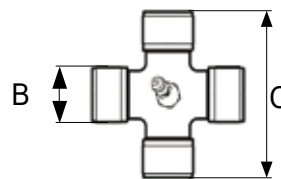

ŠIFRA ZA NAROČILO	VELIKOST	B mm	C mm	OPIS sklopka prostotekoča z:
210643	T2	23,8	61,3	desnim prostim tekom
210644	T2	23,8	61,3	levim prostim tekom
175761	T3	27	74,6	desnim prostim tekom
175762	T3	27	74,6	levim prostim tekom
180475	T4	27	82	desnim prostim tekom
210645	T45	30,2	79,4	desnim prostim tekom
210646	T45	30,2	79,4	levim prostim tekom
175774	T5	30,2	91,4	desnim prostim tekom
175775	T5	30,2	91,4	levim prostim tekom
180321	T7	35	106	desnim prostim tekom
180322	T7	35	106	levim prostim tekom
210647	T8	41	118	desnim prostim tekom
210648	T8	41	118	levim prostim tekom

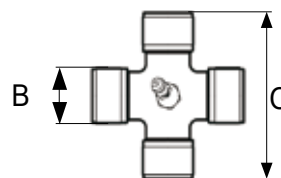

ŠIFRA ZA NAROČILO	VELIKOST	B mm	C mm	OPIS sklopka prostotekoča z:
211795	T8	41	118	desnim prostim tekom



ŠIFRA ZA NAROČILO	OPIS
175963	sklopka prostotekoča nasadna z DESNIM prostim tekom
181751	sklopka prostotekoča nasadna z LEVIM prostim tekom

ŠIFRA ZA NAROČILO	OPIS
210787	sklopka prostotekoča nasadna z DESNIM prostim tekom



ŠIFRA ZA NAROČILO	VELIKOST	OPIS
177144	T1 - T5	set zaklopa in vzmeti za sklopko prostotekočo

ŠIFRA ZA NAROČILO	VELIKOST	OPIS
181752	T7 - T8	set zaklopa in vzmeti za sklopko prostotekočo

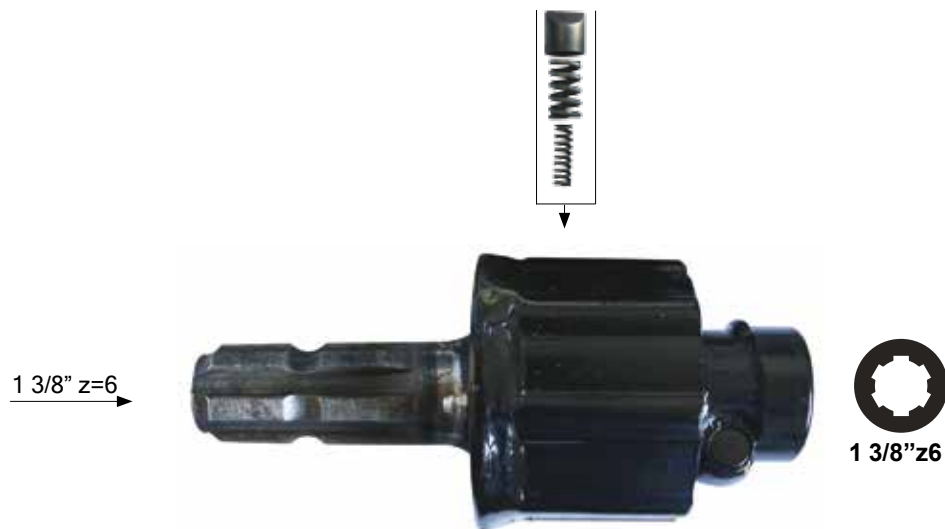

ŠIFRA ZA NAROČILO	VELIKOST	B mm	C mm	MOMENT				OPIS
175853	T12, T2	23,8	61,3	500Nm	14	14	14	sklopka zvezdasta
175855	T12, T2	23,8	61,3	600Nm	16	16	16	sklopka zvezdasta
211598	T2	23,8	61,3	750Nm	20	20	20	sklopka zvezdasta
175763	T3	27	74,6	600Nm	16	16	16	sklopka zvezdasta
175764	T3	27	74,6	900Nm	24	24	24	sklopka zvezdasta
211444	T3	27	74,6	1100Nm	29	29	29	sklopka zvezdasta
180477	T4	27	82	900Nm	24	24	24	sklopka zvezdasta
180488	T4	27	82	1000Nm	27	27	27	sklopka zvezdasta
210649	T45	30,2	79,4	900Nm	24	24	24	sklopka zvezdasta
210650	T45	30,2	79,4	1000Nm	27	27	27	sklopka zvezdasta
210651	T45	30,2	79,4	1200Nm	32	32	32	sklopka zvezdasta
210652	T45	30,2	79,4	1500Nm	40	40	40	sklopka zvezdasta
175782	T5	30,2	91,4	600Nm	16	16	16	sklopka zvezdasta
177076	T5	30,2	91,4	900Nm	24	24	24	sklopka zvezdasta
177138	T5	30,2	91,4	1000Nm	27	27	27	sklopka zvezdasta
175784	T5	30,2	91,4	1200Nm	32	32	32	sklopka zvezdasta
210653	T5	30,2	91,4	1500Nm	40	40	40	sklopka zvezdasta



ŠIFRA ZA NAROČILO	MOMENT				OPIS
181760	600Nm	16	16	16	sklopka zvezdasta nasadna
176055	900Nm	24	24	24	sklopka zvezdasta nasadna
181761	1200Nm	32	32	32	sklopka zvezdasta nasadna

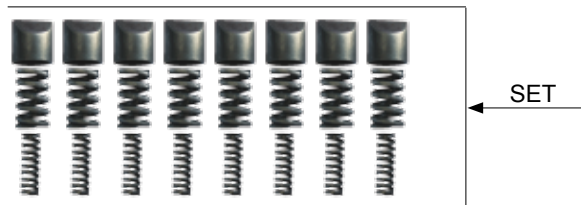

ŠIFRA ZA NAROČILO	VELIKOST	MOMENT	OPIS
176455	T1-T7	300Nm	set 8 zatikov in vzmeti za sklopko zvezdasto

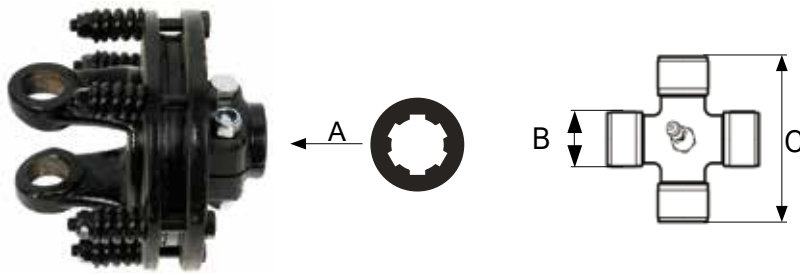

ŠIFRA ZA NAROČILO	VELIKOST	A	B mm	C mm	ŠTEVILO LAMEL	OPIS	MOMENT
182461	T2	1 3/8" z=6	23,8	61,3	2	sklopka lamelna	400Nm
180350	T3	1 3/8" z=6	27	74,6	2	sklopka lamelna	750Nm
180357	T3	1 3/8" z=6	27	74,6	2	sklopka lamelna	900Nm
180362	T5	1 3/8" z=6	30,2	91,4	2	sklopka lamelna	1200Nm
180365	T7	1 3/4" z=6	35	106	2	sklopka lamelna	1200Nm
180368	T7	1 3/8" z=6	35	106	4	sklopka lamelna	1700Nm
180369	T7	1 3/4" z=6	35	106	4	sklopka lamelna	1700Nm
180374	T8	1 3/4" z=6	41	118	4	sklopka lamelna	1700Nm



ŠIFRA ZA NAROČILO	MOMENT	ŠTEVILO LAMEL in DIMENZIJE	OPIS
181775	1200Nm	2 (165x89x4,8)	sklopka lamelna nasadna
181776	1700Nm	4 (165x89x4,8)	sklopka lamelna nasadna

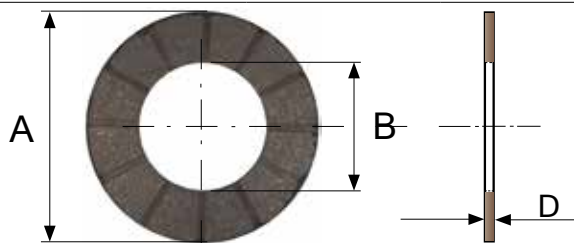

ŠIFRA ZA NAROČILO	VELIKOST	A mm	B mm	D mm	OPIS
182419	T12, T2	90	56	5	lamela
182462	T3, T4	120	80	4,8	lamela
182463	T5	150	90	4,8	lamela
182464	T7, T8	165	97	4,8	lamela
182418	T6	165	89	4,8	lamela
182427	/	160	100	4,8	lamela
182429	/	160	102	4,8	lamela

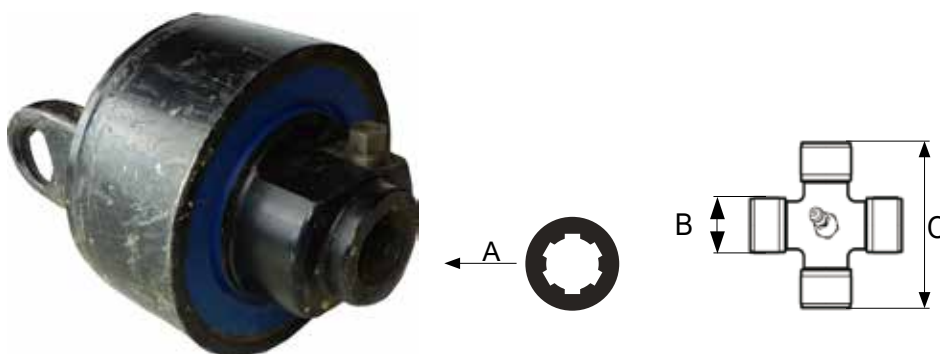

ŠIFRA ZA NAROČILO	VELIKOST	A mm	B mm	C mm	MOMENT	OPIS
210788	T7	1 3/8" z=6	35	106	1650Nm	sklopka avtomatska kompletna
210676	T7	1 3/8" z=6	35	106	1850Nm	sklopka avtomatska kompletna
210655	T7	1 3/8" z=6	35	106	2150Nm	sklopka avtomatska kompletna
210789	T7	1 3/8" z=6	35	106	2650Nm	sklopka avtomatska kompletna
210791	T7	1 3/4" z=6	35	106	2650Nm	sklopka avtomatska kompletna
210792	T8	1 3/8" z=6	41	118	2650Nm	sklopka avtomatska kompletna
210793	T8	1 3/4" z=6	41	118	2650Nm	sklopka avtomatska kompletna

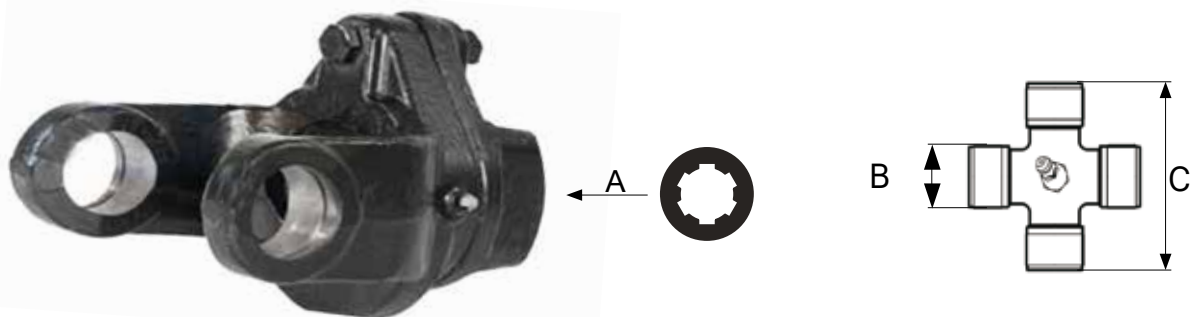

ŠIFRA ZA NAROČILO	VELIKOST	A	B mm	C mm	MOMENT	OPIS
175857	T12, T2	1 3/8" z=6	23,8	61,3	900Nm	sklopka s strižnim vijakom
175859	T3	1 3/8" z=6	27	74,6	1300Nm	sklopka s strižnim vijakom
176442	T3	1 3/8" z=6	27	74,6	1700Nm	sklopka s strižnim vijakom
180479	T4	1 3/8" z=6	27	82	1900Nm	sklopka s strižnim vijakom
210702	T45	1 3/8" z=6	30,2	79,4	2200Nm	sklopka s strižnim vijakom
175875	T5	1 3/8" z=6	30,2	91,4	2500Nm	sklopka s strižnim vijakom
177079	T7	1 3/8" z=6	35	106	3500Nm	sklopka s strižnim vijakom
178682	T7	1 3/4" z=6	35	106	3500Nm	sklopka s strižnim vijakom
210654	T8	1 3/8" z=6	41	118	4500Nm	sklopka s strižnim vijakom



ŠIFRA ZA NAROČILO	VELIKOST	OPIS
177119	T12, T2	Set 3 vijakov in matic za strižno sklopko 900Nm
177124	T3	Set 3 vijakov in matic za strižno sklopko 1300Nm
177126	T4	Set 3 vijakov in matic za strižno sklopko 1700Nm
177126	T45	Set 3 vijakov in matic za strižno sklopko 2200Nm
177130	T5	Set 3 vijakov in matic za strižno sklopko 2500Nm
177135	T7	Set 3 vijakov in matic za strižno sklopko 3500Nm
210795	T8	Set 3 vijakov in matic za strižno sklopko 4500Nm

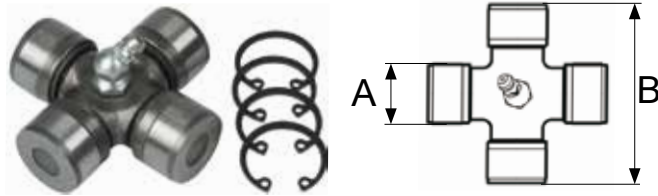

ŠIFRA ZA NAROČILO	VELIKOST	A mm	B mm	OPIS
950983	T1	22	54	križ kardana mazanje na sredini
200127	T12, T2	23,8	61,3	križ kardana mazanje na sredini
960583	T3	27	74,6	križ kardana mazanje na sredini
180445	T4	27	82	križ kardana mazanje na sredini
177196	T45	30,2	79,4	križ kardana mazanje na sredini
175768	T5	30,2	91,4	križ kardana mazanje na sredini
175787	T7	35	106	križ kardana mazanje na sredini
180290	T8	41	118	križ kardana mazanje na sredini

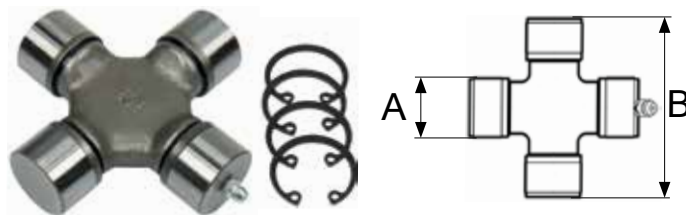

ŠIFRA ZA NAROČILO	VELIKOST	A mm	B mm	OPIS
181650	T12, T2	23,8	61,3	križ kardana mazanje s strani
181649	T3	27	74,6	križ kardana mazanje s strani
181651	T4	27	82	križ kardana mazanje s strani
181652	T45	30,2	79,4	križ kardana mazanje s strani
182387	T5	30,2	91,4	križ kardana mazanje s strani
175924	T5	30,2	99,4	križ kardana mazanje s strani
210656	T7	35	106	križ kardana mazanje s strani



ŠIFRA ZA NAROČILO	VELIKOST	A mm	B mm	C mm	D mm	OPIS
210817	T2	23,4	75,7	22	59,3	križ kardana mazanje s strani
210819	T7	35	113	35	106,3	križ kardana mazanje s strani

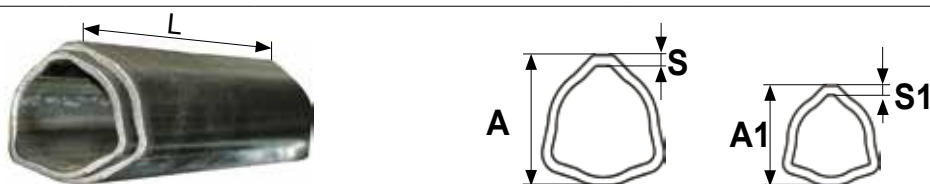

ŠIFRA ZA NAROČILO	VELIKOST	AxS mm	A1xS1 mm	L mm	OPIS
180490	T1, T12	36 x 3,2	29 x 4	550	cev v cevi - set
180497	T1, T12	36 x 3,2	29 x 4	750	cev v cevi - set
180505	T1, T12	36 x 3,2	29 x 4	1200	cev v cevi - set
180491	T2, T3	43,5 x 3,4	36 x 4,5	550	cev v cevi - set
180498	T2, T3	43,5 x 3,4	36 x 4,5	750	cev v cevi - set
180507	T2, T3	43,5 x 3,4	36 x 4,5	1200	cev v cevi - set
180448	T4, T45	51,5 x 3	45 x 3,8	550	cev v cevi - set
180450	T4, T45	51,5 x 3	45 x 3,8	750	cev v cevi - set
180451	T4, T45	51,5 x 3	45 x 3,8	1200	cev v cevi - set
180493	T5	54 x 4	45 x 5,5	550	cev v cevi - set
180500	T5	54 x 4	45 x 5,5	750	cev v cevi - set
180476	T5	54 x 4	45 x 5,5	1200	cev v cevi - set
180495	T7, T8	63 x 4	54 x 5	550	cev v cevi - set
180503	T7, T8	63 x 4	54 x 5	750	cev v cevi - set
180508	T7, T8	63 x 4	54 x 5	1200	cev v cevi - set

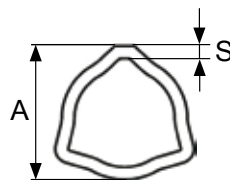

ŠIFRA ZA NAROČILO	VELIKOST	AxS mm	L mm	OPIS
175739	T1, T12	36 x 3,2	3000	cev posamična - zunanja
175740	T1, T12	29 x 4	3000	cev posamična - notranja
175753	T3	43,5 x 3,4	3000	cev posamična - zunanja
175754	T3	36 x 4,5	3000	cev posamična - notranja
175772	T5	54 x 4	3000	cev posamična - zunanja
175773	T5	45 x 5,5	3000	cev posamična - notranja
175794	T7, T8	63 x 4	3000	cev posamična - zunanja
175795	T7, T8	54 x 5	3000	cev posamična - notranja

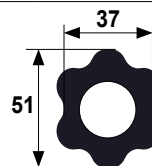
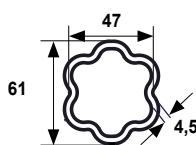
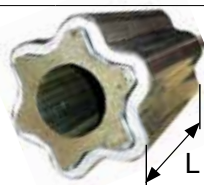

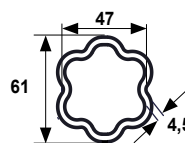
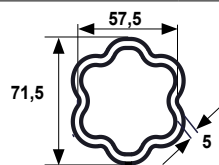
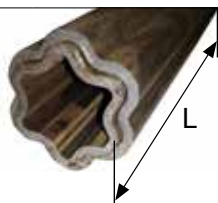

ŠIFRA ZA NAROČILO	VELIKOST	cev zunanja	cev notranja	L mm	OPIS
210657	X7	61 x 47 x 4,5	51 x 37	500	cev v cevi - set
210658	X7	61 x 47 x 4,5	51 x 37	750	cev v cevi - set
210659	X7	61 x 47 x 4,5	51 x 37	1000	cev v cevi - set
210660	X7	61 x 47 x 4,5	51 x 37	1500	cev v cevi - set

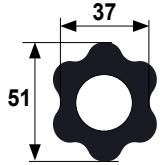

ŠIFRA ZA NAROČILO	VELIKOST	cev zunanja	cev notranja	L mm	OPIS
210661	X8	71,5 x 57,5 x 5	61 x 47 x 4,5	500	cev v cevi - set
210662	X8	71,5 x 57,5 x 5	61 x 47 x 4,5	750	cev v cevi - set
210663	X8	71,5 x 57,5 x 5	61 x 47 x 4,5	1000	cev v cevi - set
210664	X8	71,5 x 57,5 x 5	61 x 47 x 4,5	1500	cev v cevi - set

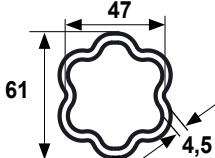
		
ŠIFRA ZA NAROČILO	L mm	OPIS
210665	3000	cev posamična zvezdasta - notranja

		
ŠIFRA ZA NAROČILO	L mm	OPIS
210667	3000	cev posamična zvezdasta, uporaba kot zunanja ali notranja

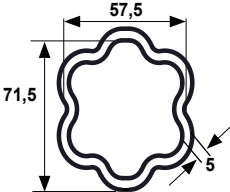
		
ŠIFRA ZA NAROČILO	L mm	OPIS
210668	3000	cev posamična zvezdasta - zunanja

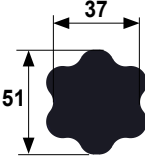
		
ŠIFRA ZA NAROČILO	L mm	OPIS
210666	3000	palica posamična zvezdasta - notranja

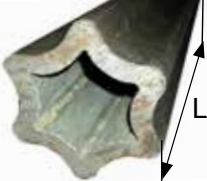
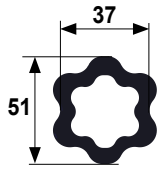
		
ŠIFRA ZA NAROČILO	L mm	OPIS
211941	3000	cev posamična zvezdasta - notranja

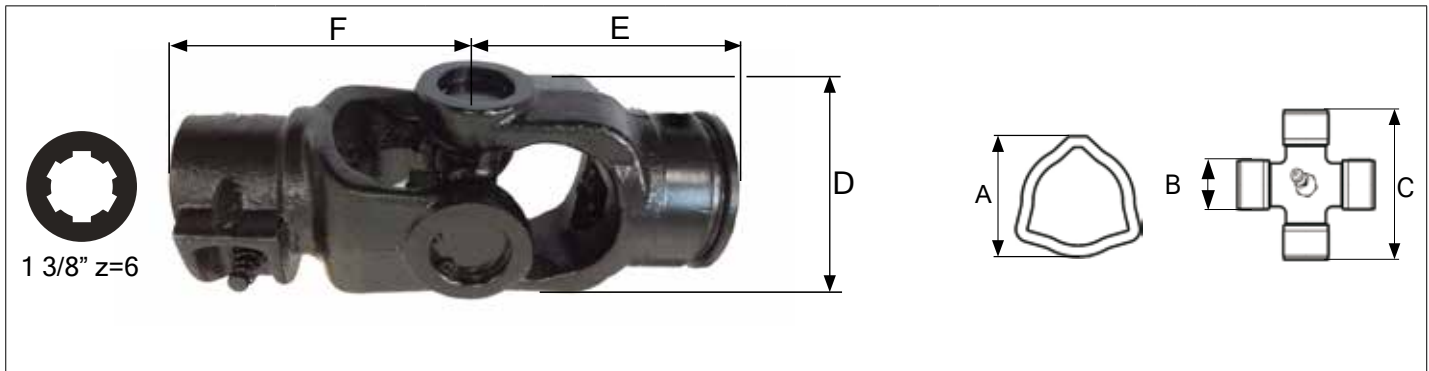

ŠIFRA ZA NAROČILO	VELIKOST	D	E	F	KRIŽ BxC	ZA CEV TRIKOTNO A	OPIS
210678	T1	63	92	92	22x54	NOTRANJO 29	zglob kompleten
210679	T1	63	92	92	22x54	ZUNANJO 36	zglob kompleten
210680	T12	72	100	92	23,8x61,3	NOTRANJO 29	zglob kompleten
210681	T12	72	100	92	23,8x61,3	ZUNANJO 36	zglob kompleten
210682	T2	72	100	92	23,8x61,3	NOTRANJO 36	zglob kompleten
210683	T2	72	100	92	23,8x61,3	ZUNANJO 43,5	zglob kompleten
210684	T3	86	107	90	27x74,6	NOTRANJO 36	zglob kompleten
210685	T3	86	107	90	27x74,6	ZUNANJO 43,5	zglob kompleten
210686	T45	90	113	96	30,2x79,4	NOTRANJO 45	zglob kompleten
210687	T45	90	113	96	30,2x79,4	ZUNANJO 51,5	zglob kompleten
210688	T5	104	118	108	30,2x91,4	NOTRANJO 45	zglob kompleten
210689	T5	104	118	108	30,2x91,4	ZUNANJO 54	zglob kompleten
210690	T7	119	128	112,5	35x106	NOTRANJO 54	zglob kompleten
210691	T7	119	128	112,5	35x106	ZUNANJO 63	zglob kompleten
210692	T8	130	135	137	41x118	NOTRANJO 54	zglob kompleten
210693	T8	130	135	137	41x118	ZUNANJO 63	zglob kompleten



← A

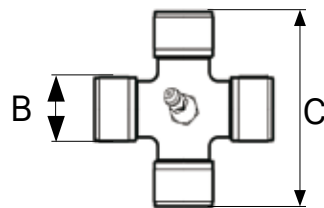
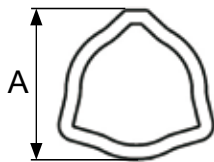

ŠIFRA ZA NAROČILO	VELIKOST	B mm	C mm	VILICA MONTIRANA NA CEVI A	OPIS
175737	T1	22	54	zunANJI 36	vilica notranja
175738	T1	22	54	notranji 29	vilica notranja
175850	T12	23,8	61,3	zunANJI 36	vilica notranja
175851	T12	23,8	61,3	notranji 29	vilica notranja
210858	T2	23,8	61,3	zunANJI 43,5	vilica notranja
210859	T2	23,8	61,3	notranji 36	vilica notranja
175751	T3	27	74,6	zunANJI 43,5	vilica notranja
175752	T3	27	74,6	notranji 36	vilica notranja
180446	T4	27	82	zunANJI 51,5	vilica notranja
180447	T4	27	82	notranji 45	vilica notranja
180463	T45	30,2	79,4	zunANJI 51,5	vilica notranja
180464	T45	30,2	79,4	notranji 45	vilica notranja
175770	T5	30,2	91,4	zunANJI 54	vilica notranja
175771	T5	30,2	91,4	notranji 45	vilica notranja
175792	T7	35	106	zunANJI 63	vilica notranja
175793	T7	35	106	notranji 54	vilica notranja
182396	T8	41	118	zunANJI 63	vilica notranja
182397	T8	41	118	notranji 54	vilica notranja

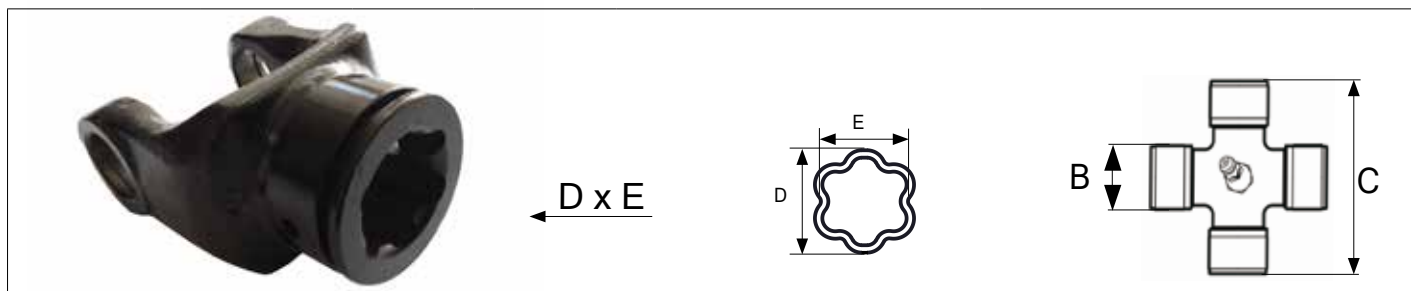

ŠIFRA ZA NAROČILO	VELIKOST	B mm	C mm	VILICA MONTIRANA NA CEVI D x E	OPIS
210798	X7	35	106	notranja 51x37	vilica notranja
210799	X7	35	106	zunanja 61x47	vilica notranja
210800	X8	41	118	notranja 61x47	vilica notranja
210801	X8	41	118	zunanja 71,5x57,5	vilica notranja

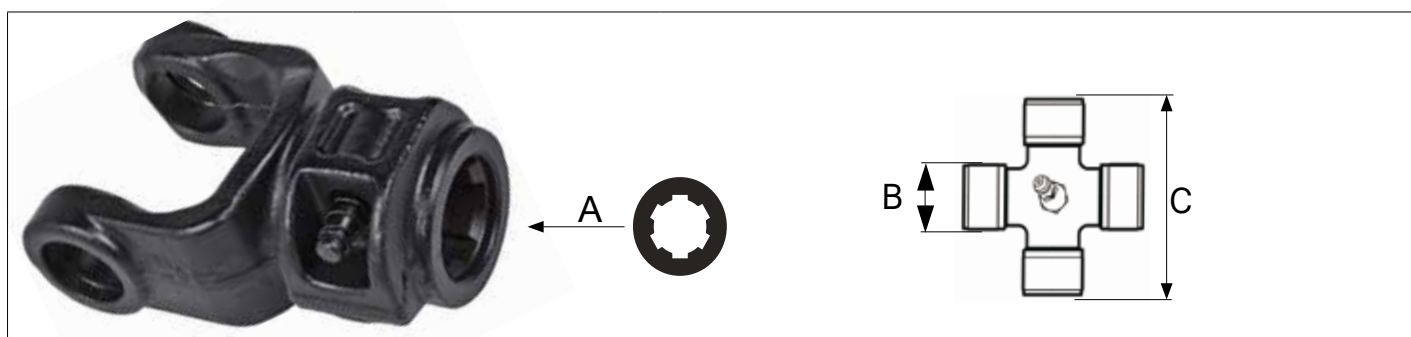

ŠIFRA ZA NAROČILO	VELIKOST	A	B mm	C mm	OPIS
175736	T1	1 3/8" z=6	22	54	vilica zunanja kompletna
175849	T12, T2	1 3/8" z=6	23,8	61,3	vilica zunanja kompletna
175750	T3	1 3/8" z=6	27	74,6	vilica zunanja kompletna
191413	T3	1 3/8" z=21	27	74,6	vilica zunanja kompletna
180444	T4	1 3/8" z=6	27	82	vilica zunanja kompletna
180462	T45	1 3/8" z=6	30,2	79,4	vilica zunanja kompletna
175769	T5	1 3/8" z=6	30,2	91,4	vilica zunanja kompletna
177143	T5	1 3/8" z=21	30,2	91,4	vilica zunanja kompletna
182938	T5	1 3/4" z=6	30,2	91,4	vilica zunanja kompletna
175789	T7	1 3/8" z=6	35	106	vilica zunanja kompletna
177839	T7	1 3/8" z=21	35	106	vilica zunanja kompletna
177840	T7	1 3/4" z=6	35	106	vilica zunanja kompletna
177841	T8	1 3/8" z=6	41	118	vilica zunanja kompletna
177842	T8	1 3/4" z=6	41	118	vilica zunanja kompletna

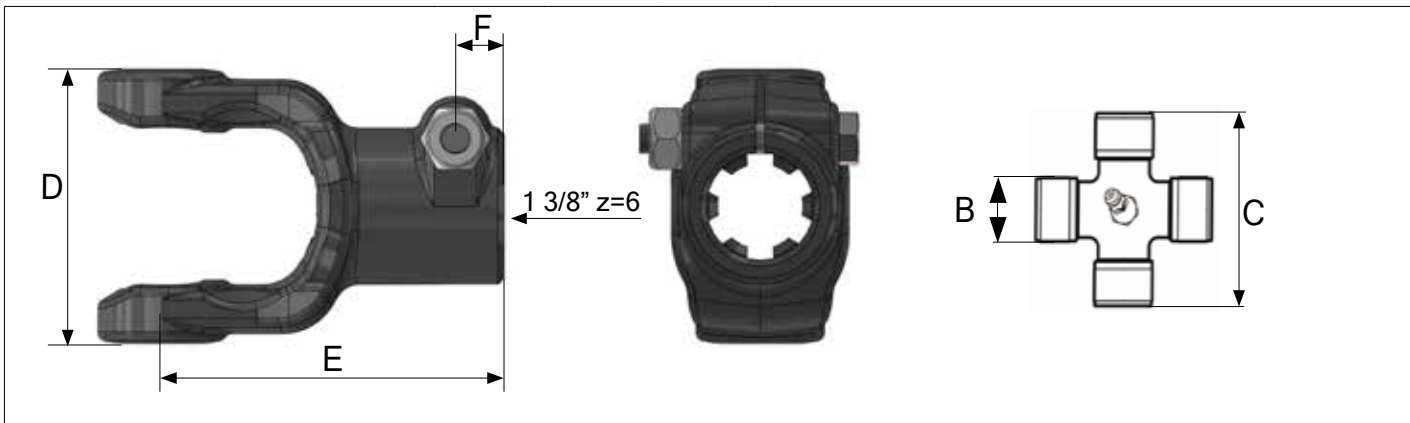

ŠIFRA ZA NAROČILO	VELIKOST	B mm	C mm	D mm	E mm	F mm	OPIS
210669	T3	27	74,6	86	107	24	vilica zunanja kompletna
210670	T45	30,2	79,4	90	113	20	vilica zunanja kompletna
210671	T5	30,2	91,4	104	118	24	vilica zunanja kompletna



ŠIFRA ZA NAROČILO	VELIKOST	B mm	C mm	D mm	E mm	F mm	G mm	H mm	OPIS
210672	T2	23,8	61,3	72	100	20	30	10	vilica zunanja kompletna
210673	T2	23,8	61,3	72	100	20	25	10	vilica zunanja kompletna
210674	T3	27	74,6	86	107	20	35	10	vilica zunanja kompletna
210675	T3	27	74,6	86	107	20	30	10	vilica zunanja kompletna
210677	T5	30,2	91,4	104	118	20	35	10	vilica zunanja kompletna



175826

175827

ŠIFRA ZA NAROČILO	VELIKOST	OPIS
175826	T1 - T7	Zatič
175827	T1 - T7	Vzmet



183031

ŠIFRA ZA NAROČILO	VELIKOST	OPIS
183031	T5 - T7	Zapiralo - set s plastičnem obročem



183032

ŠIFRA ZA NAROČILO	VELIKOST	OPIS
183032	T2 - T7	Zapiralo - set s kovinskim obročem



183033

ŠIFRA ZA NAROČILO	VELIKOST	OPIS
183033	T2 -T7	Zapiralo - set s kovinskim obročem



180302

ŠIFRA ZA NAROČILO	VELIKOST	OPIS
180302	T8	Zapiralo vzemt-zatič

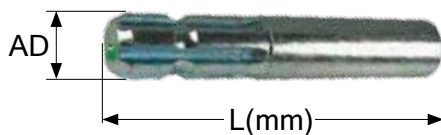

ŠIFRA ZA NAROČILO	L (mm)	AD	OPIS
961246	120	1 3/8" z=6	gred kardanska priključna
961248	200	1 3/8" z=6	gred kardanska priključna
961247	300	1 3/8" z=6	gred kardanska priključna

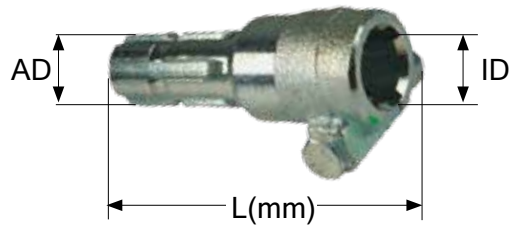

ŠIFRA ZA NAROČILO	L (mm)	AD	ID	OPIS
960856	160	1 3/8" z=6	1 3/8" z=6	podaljšek kardana na vijak
950094	160	1 3/8" z=6	1 3/8" z=21	podaljšek kardana na vijak

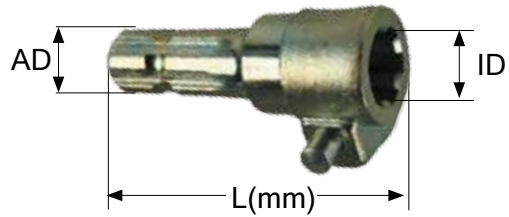

ŠIFRA ZA NAROČILO	L (mm)	AD	ID	OPIS
970611	150	1 3/8" z=6	1 3/8" z=6	podaljšek kardana na zatič



ŠIFRA ZA NAROČILO	L (mm)	AD	ID	OPIS
175933	175	1 3/8" z=6	1 3/8" z=6	podaljšek kardana z zapiralom

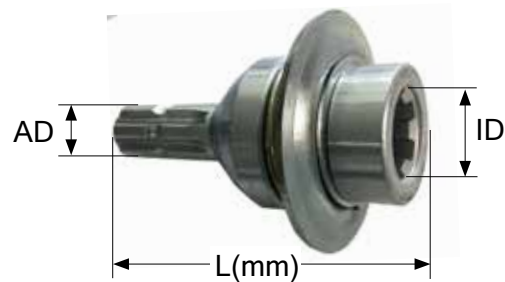

ŠIFRA ZA NAROČILO	L (mm)	AD	ID	OPIS
194478	180	1 3/8" z=6	1 3/4" z=6	podaljšek kardana z zapiralom

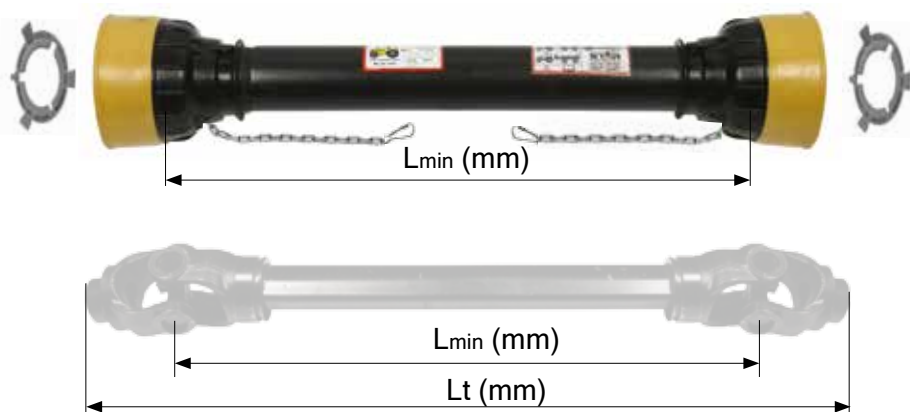

ŠIFRA ZA NAROČILO	VELIKOST	L_{min} (mm)	Uporaba za kardanove do celotne dolžine L_t :	OPIS
175741	T1, T12, T2	660	860	zaščita z ležajema in verižicama
177066	T1, T12, T2	1210	1410	zaščita z ležajema in verižicama
175755	T3	760	974	zaščita z ležajema in verižicama
177068	T3	1586	1800	zaščita z ležajema in verižicama
181351	T4	660	878	zaščita z ležajema in verižicama
181353	T4	1382	1600	zaščita z ležajema in verižicama
181354	T45	660	886	zaščita z ležajema in verižicama
181356	T45	1374	1600	zaščita z ležajema in verižicama
175821	T5	760	996	zaščita z ležajema in verižicama
177077	T5	1364	1600	zaščita z ležajema in verižicama
177078	T7	1110	1366	zaščita z ležajema in verižicama
180392	T8	760	1030	zaščita z ležajema in verižicama
210694	T8	1530	1800	zaščita z ležajema in verižicama

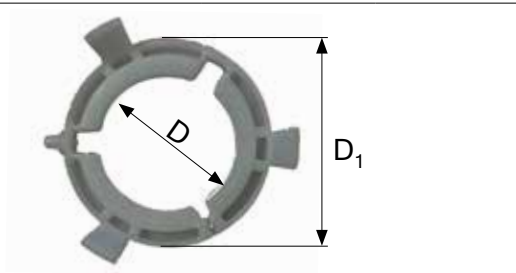

ŠIFRA ZA NAROČILO	VELIKOST	D mm	D1 mm	OPIS
175889	T1, T12, T2	46	78	ležaj plastični
175892	T3	53	78	ležaj plastični
180656	T4	53	93	ležaj plastični
175894	T45, T5, T7	60	96	ležaj plastični
175895	T5, T7	70	96	ležaj plastični
175898	T8	75	96	ležaj plastični



RAZPOREDITEV LEŽAJEV GLEDE NA VELIKOST KARDANA IN STRAN MONTAŽE		
STRAN TRAKTORJA Dmm/D1mm	ZA VELIKOST KARDANA	STRAN PRIKLJUČKA Dmm/D1mm
46/78	T1, T12, T2	46/78
53/78	T3	53/78
53/93	T4	53/93
60/96	T45	60/96
70/96	T5, T7	60/96
75/96	T8	75/96



ŠIFRA ZA NAROČILO	VELIKOST	dolžina verige L (mm)	OPIS
177803	T1-T8	350	veriga varovalna zaščite kardana

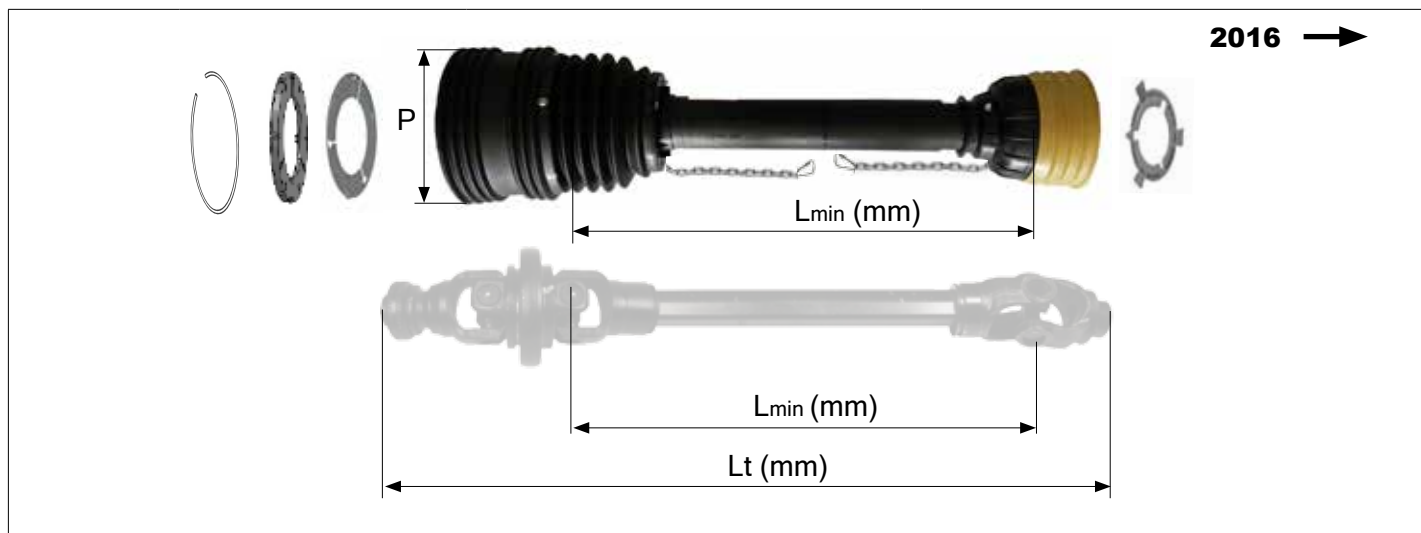

ŠIFRA ZA NAROČILO	VELIKOST	L _{min} (mm)	Uporaba za kardane do celotne dolžine Lt:	P (mm)	OPIS
210695	T2	1192	1500	185	Zaščita kompletna z ležaji plastičnimi in verižicama
210696	T5	1117	1500	212	Zaščita kompletna z ležaji plastičnimi in verižicama
210697	T7	1114	1500	236	Zaščita kompletna z ležaji plastičnimi in verižicama

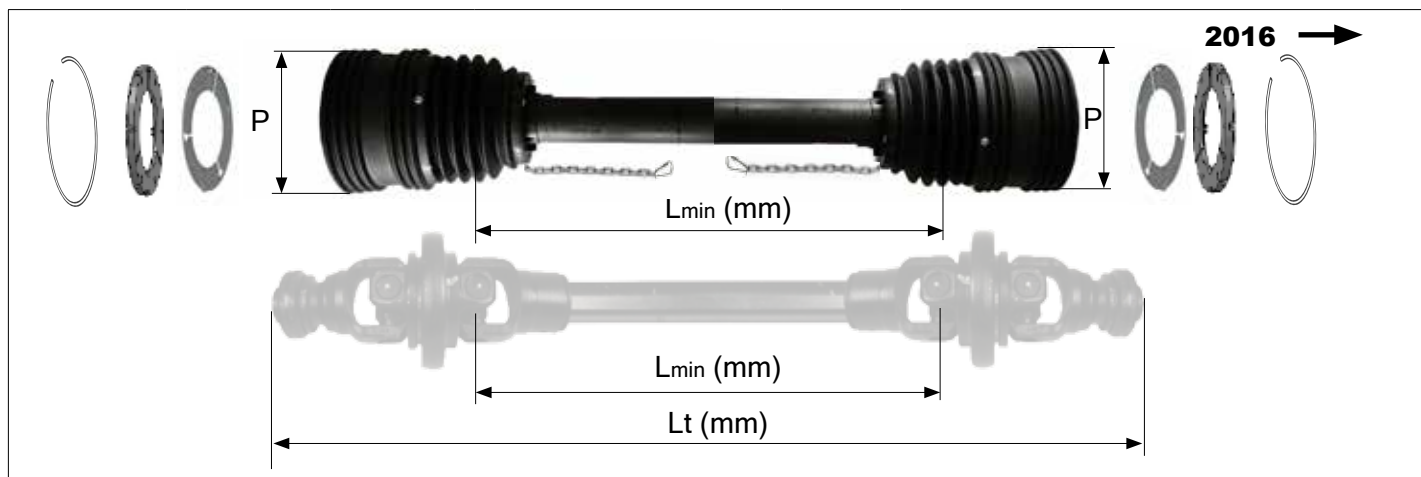

ŠIFRA ZA NAROČILO	SIZE	L _{min} (mm)	Uporaba za kardane do celotne dolžine Lt:	P (mm)	OPIS
210698	T2	1380	1800	185	Zaščita kompletna z ležaji plastičnimi in verižicama
210699	T5	1290	1800	212	Zaščita kompletna z ležaji plastičnimi in verižicama
210700	T7	1284	1800	236	Zaščita kompletna z ležaji plastičnimi in verižicama



ŠIFRA ZA NAROČILO	VELIKOST	KOSOV	POZICIJA	OPIS
211105	T2	1	A	Vzmetni obroč Ø 181mm - Ø 4mm
211106	T5	1	A	Vzmetni obroč Ø 219mm - Ø 4mm
211107	T7	1	A	Vzmetni obroč Ø 235mm - Ø 5mm
210831	T2	1	B	Ležaj plastični S2, 102 x 164 x 11
210832	T5	1	B	Ležaj plastični S5, 187 x 128 x 13
210833	T7	1	B	Ležaj plastični S7, 207 x 148 x 13
210805	T2, T5, T7	9	C	Vijaki 4,8 x 19
210834	T2	1	D	Zaščita gibljiva, P=185mm
210835	T5	1	D	Zaščita gibljiva, P=212mm
210836	T7	1	D	Zaščita gibljiva, P=236mm
181707	T2	1	E	Ležaj plastični S2, 118 x 75 x 12,5
210837	T5, T7	1	E	Ležaj plastični S5 - S7, 148 x 80 x 13,5

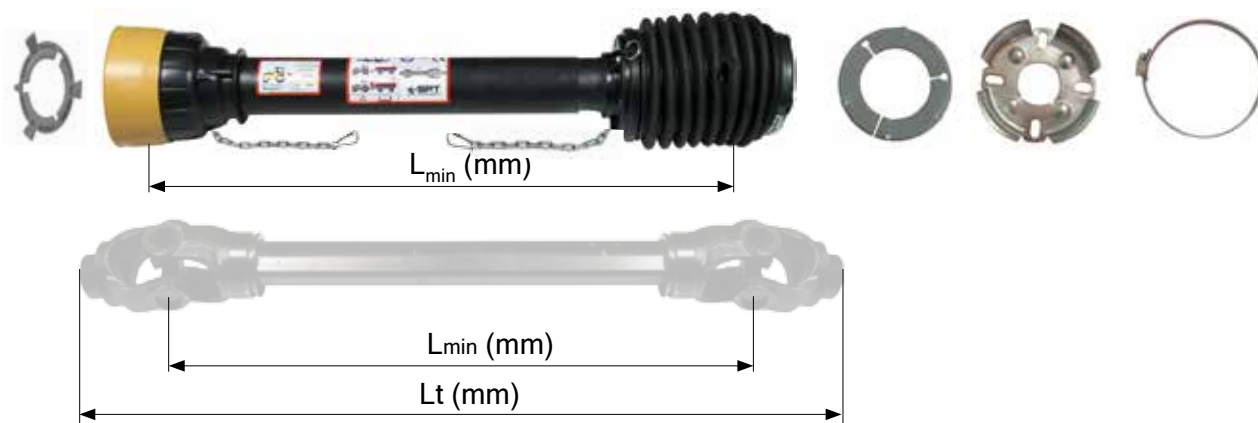

ŠIFRA ZA NAROČILO	VELIKOST	L _{min} (mm)	Uporaba za kardanane do celotne dolžine Lt:	OPIS
180691	T12, T2	860	1060	zaščita z ležajema, prirobnico, objemko in verižicama
180692	T12, T2	1260	1400	zaščita z ležajema, prirobnico, objemko in verižicama
180693	T3	860	1060	zaščita z ležajema, prirobnico, objemko in verižicama
180696	T3	1386	1600	zaščita z ležajema, prirobnico, objemko in verižicama
181689	T4	860	1078	zaščita z ležajema, prirobnico, objemko in verižicama
180694	T5	860	1096	zaščita z ležajema, prirobnico, objemko in verižicama



ŠIFRA ZA NAROČILO	VELIKOST	POZICIJA	OPIS
181705	T12, T2, T3, T4, T5	A (1+2+3+4)	prilagodljiva zaščita komplet
181708	T12, T2, T3, T4, T5	1	meh
181707	T12, T2, T3, T4, T5	2	plastični ležaj
181710	T12, T2, T3, T4, T5	3	prirobnica
181711	T12, T2, T3, T4, T5	4	objemka

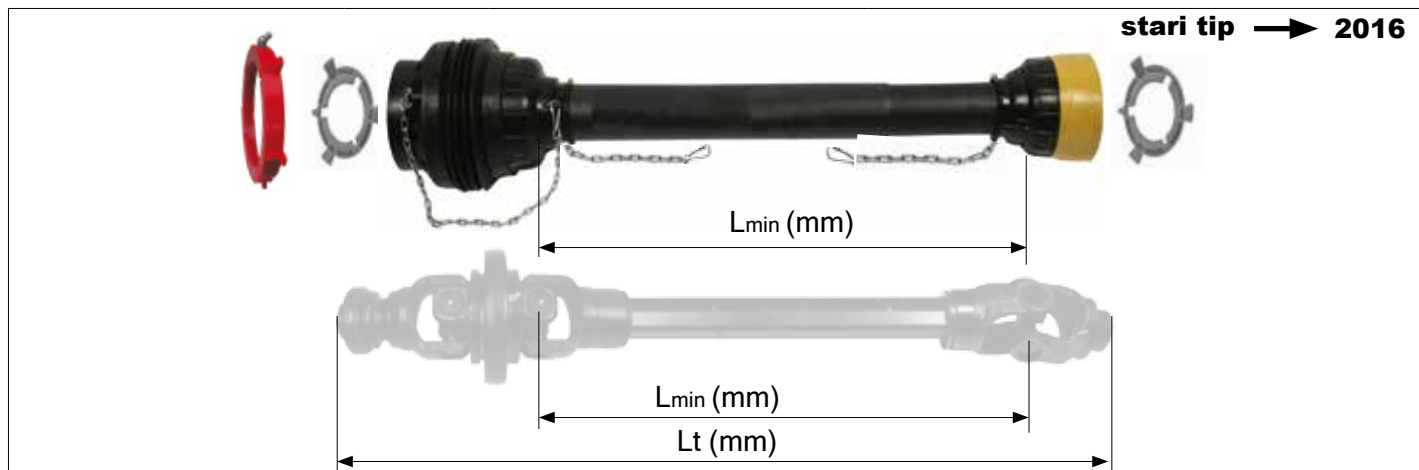

ŠIFRA ZA NAROČILO	VELIKOST	L _{min} (mm)	Uporaba za kardane do celotne dolžine Lt:	OPIS
175947	T5	860	1250	zaščita kompletna z ležaji in verižicami
175824	T5	1110	1490	zaščita kompletna z ležaji in verižicami

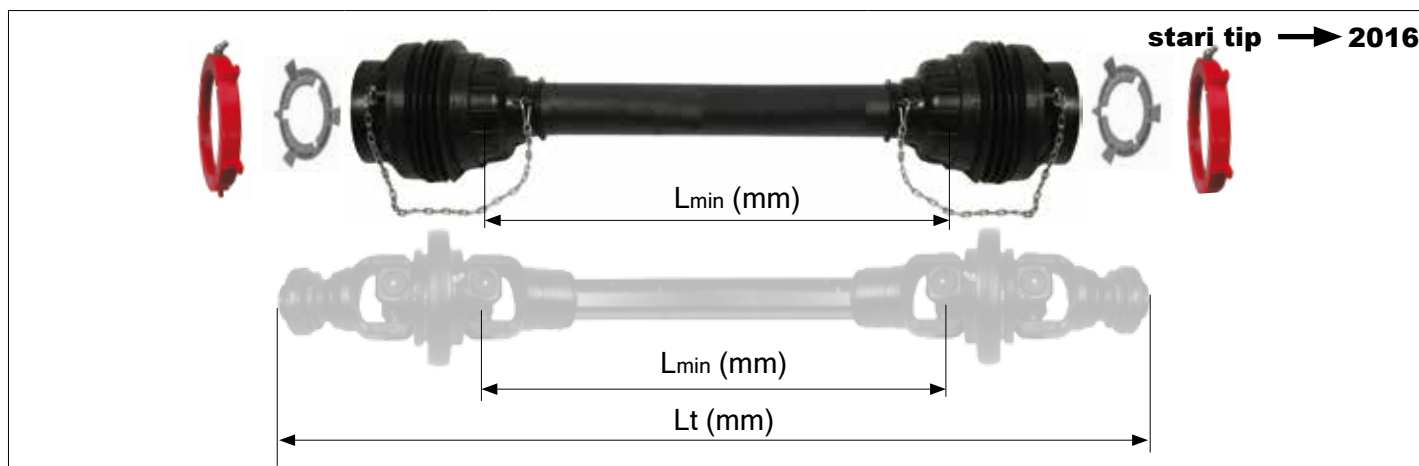

ŠIFRA ZA NAROČILO	VELIKOST	L _{min} (mm)	Uporaba za kardane do celotne dolžine Lt:	OPIS
180394	T5	1290	1800	zaščita kompletna z ležaji in verižicami



ŠIFRA ZA NAROČILO	VELIKOST	POZICIJA	OPIS
175953	T5	A (1+2+3)	zaščita za zglob 80° komplet
188096	T5	1	prirobnica plastična
188097	T5	2	ležaj dvojnega zgloba z mazalko
188098	T5	3	meh gumjasti

ZAŠČITA KARDANA

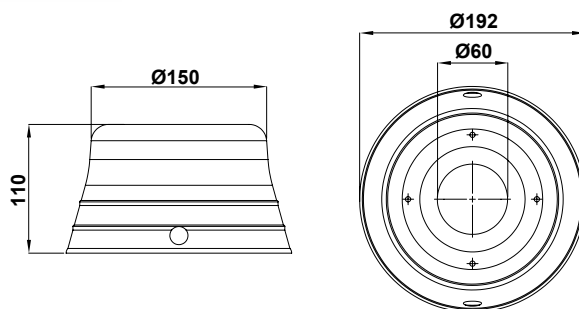

ŠIFRA ZA NAROČILO

199757

ZAŠČITA KARDANA

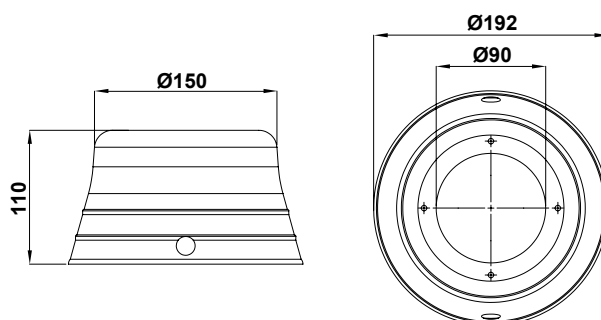

ŠIFRA ZA NAROČILO

199758

ZAŠČITA KARDANA

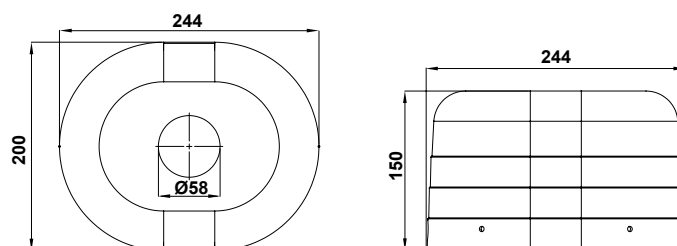

ŠIFRA ZA NAROČILO

874313

ZAŠČITA KARDANA

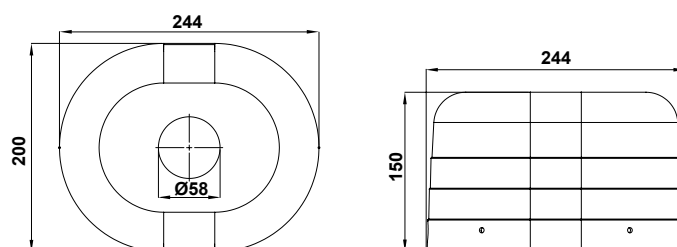

ŠIFRA ZA NAROČILO

199756

ZAŠČITA KARDANA

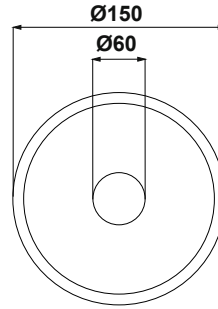
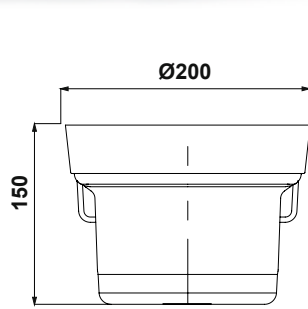

ŠIFRA ZA NAROČILO

181819

ZAŠČITA KARDANA

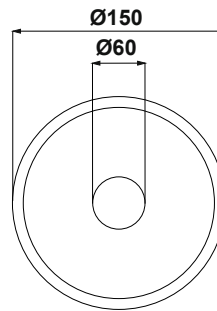
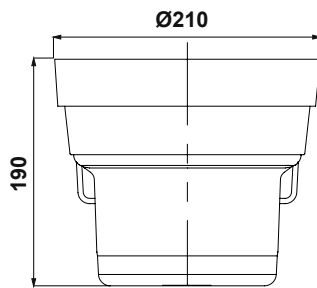

ŠIFRA ZA NAROČILO

181820

ZAŠČITA KARDANA

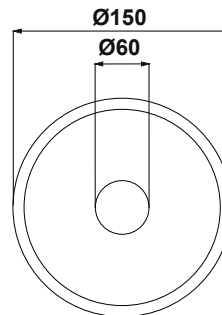
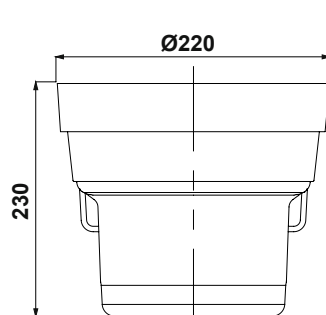

ŠIFRA ZA NAROČILO

181821

ZAŠČITA KARDANA S KOTROLNIM POKROVOM

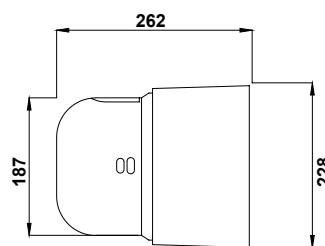
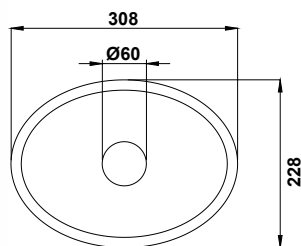

ŠIFRA ZA NAROČILO

207912

ZAŠČITA KARDANA S KOTROLNIM POKROVOM

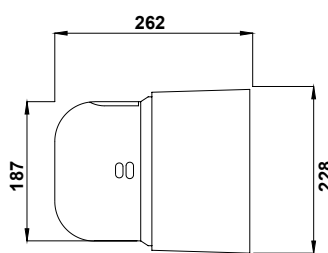
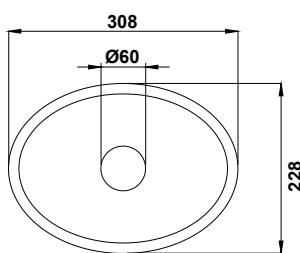

ŠIFRA ZA NAROČILO

196919

ZAŠČITA KARDANA Z UTORI ZA MONTAŽO

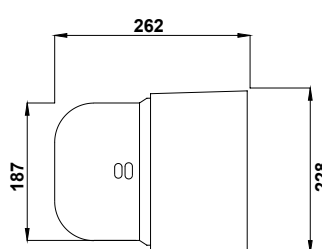
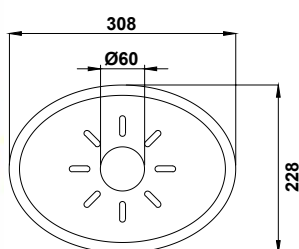

ŠIFRA ZA NAROČILO

196917

ZAŠČITA KARDANA Z UTORI ZA MONTAŽO

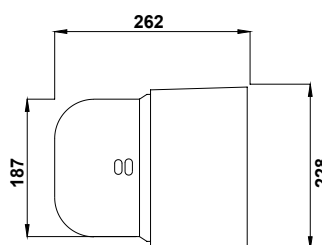
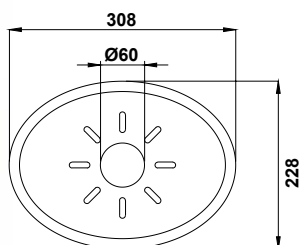

ŠIFRA ZA NAROČILO

196918

ZAŠČITA KARDANA Z UTORI ZA MONTAŽO IN KOTROLNIM POKROVOM

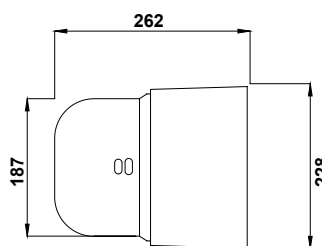
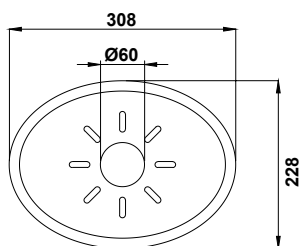

ŠIFRA ZA NAROČILO

196916

ZAŠČITA KARDANA S KOTROLNIM POKROVOM

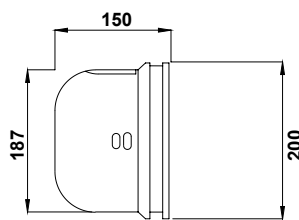
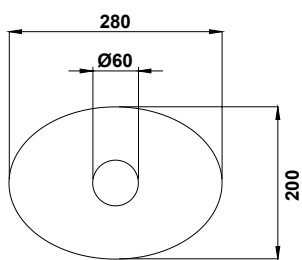

ŠIFRA ZA NAROČILO

196913

ZAŠČITA KARDANA Z UTORI ZA MONTAŽO

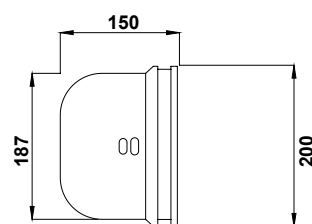
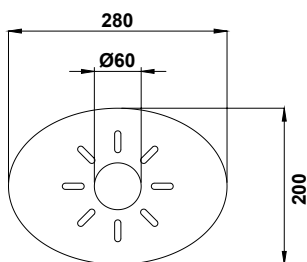

ŠIFRA ZA NAROČILO

196914

ZAŠČITA KARDANA Z UTORI ZA MONTAŽO IN KOTROLNIM POKROVOM

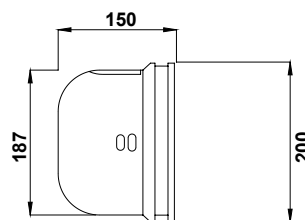
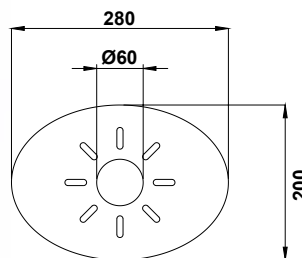

ŠIFRA ZA NAROČILO

196915

ZAŠČITA KARDANA

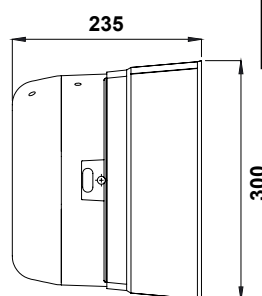
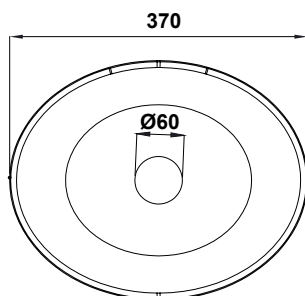

ŠIFRA ZA NAROČILO

207913

POKROV GREDI KARDANSKE (1 3/8")

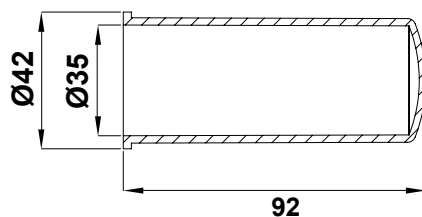

ŠIFRA ZA NAROČILO

197631

POKROV GREDI KARDANSKE (1 3/4")

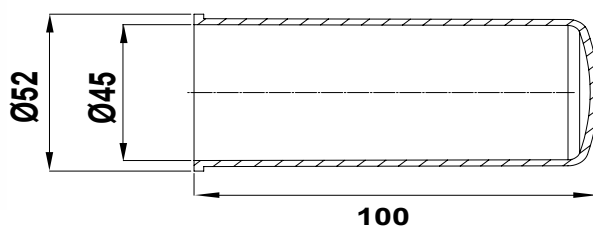

ŠIFRA ZA NAROČILO

206177

POKROV GREDI KARDANSKE

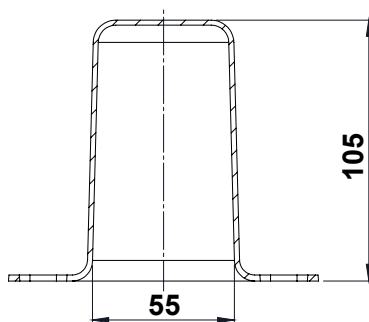

ŠIFRA ZA NAROČILO

203328

POKROV GREDI KARDANSKE

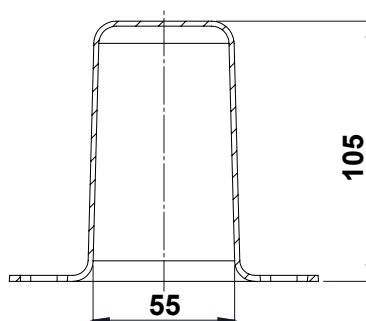

ŠIFRA ZA NAROČILO

203329

ZAŠČITA CEVNA ZA DOKUMENTE VELIKA

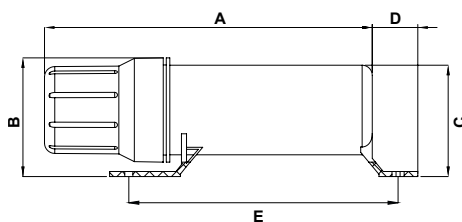

ŠIFRA ZA NAROČILO

199081

A	B	C	D	E
318	140	138	45	266

ZAŠČITA CEVNA ZA DOKUMENTE SREDNJA

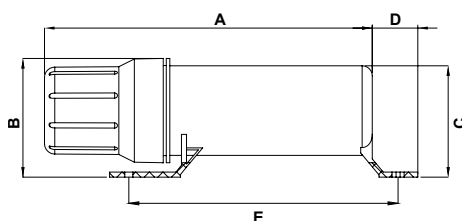

ŠIFRA ZA NAROČILO

196920

A	B	C	D	E
321	117	110	45	266

ZAŠČITA CEVNA ZA DOKUMENTE MALA

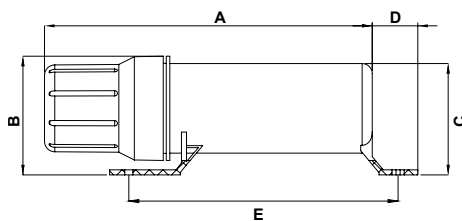

ŠIFRA ZA NAROČILO

198576

A	B	C	D	E
321	77	72	24	266



180140

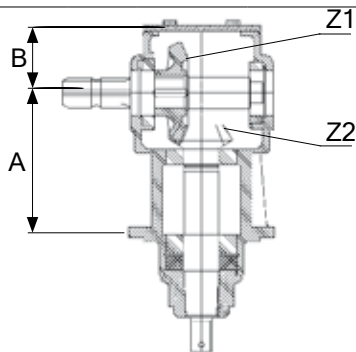

181785

ŠIFRA ZA NAROČILO	A	B	Z1	Z2	i	KW	KM	OBRATI/ min	TEŽA kg	OPIS
180140	164,87	70,13	12	23	1:1,91	22	30	540	16,5	gonilo s priključkom enostranskim za horizontalne mulčerje širine od 800 do 1200mm
181785	183,5	81	14	26	1:1,86	47,8	65	540	26,8	gonilo s priključkom enostranskim za horizontalne mulčerje širine od 1200 do 1800mm

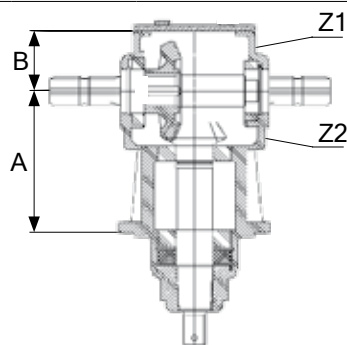

ŠIFRA ZA NAROČILO	A	B	Z1	Z2	i	KW	KM	OBRATI/ min	TEŽA kg	OPIS
203071	164,87	70,13	12	23	1:1,91	22	30	540	17	gonilo s priključkom na obeh straneh za horizontalne mulčerje širine od 800 do 1200mm

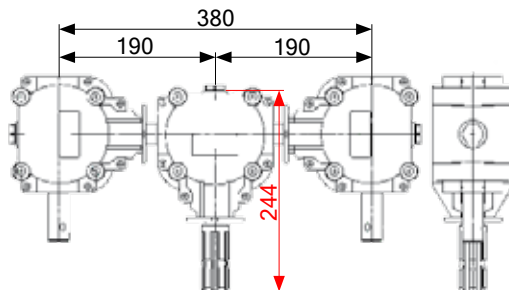

ŠIFRA ZA NAROČILO	Z1	Z2	Z3	i	KW	KM	OBRATI/ min	TEŽA kg	OPIS
181786	15	17	23	1:1,35	7	10	540	12,5	za trosilce mineralnih gnojil

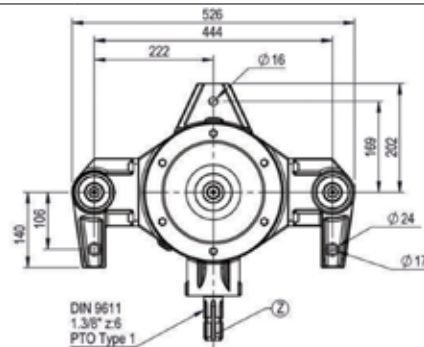

ŠIFRA ZA NAROČILO	Z1	Z2	Z3	Z4	i	OBRATI/ min	TEŽA kg	OPIS
198994	15	45	20	11	1,81:1	540	42	za trosilce mineralnih gnojil

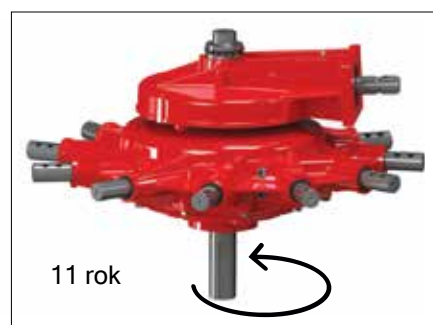
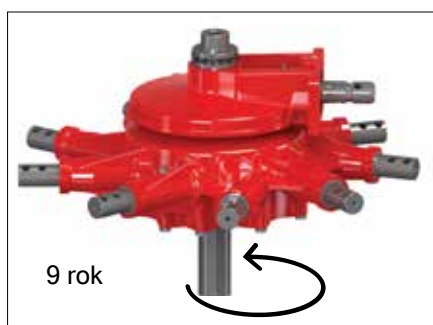

ŠIFRA ZA NAROČILO	št. rok	Z1	Z2	i	OBRATI/ min	TEŽA kg	OPIS
181787	9	72	10	7,2:1	540	70	za zgrabljalnike Minosagri, T-OT 330-9, T-OT 370-9,
181788	11	82	10	8,2:1	540	120	za zgrabljalnike Minosagri, T-OT 424-11

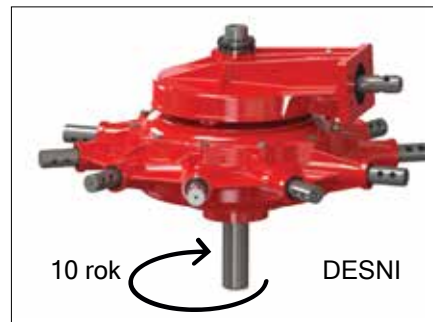
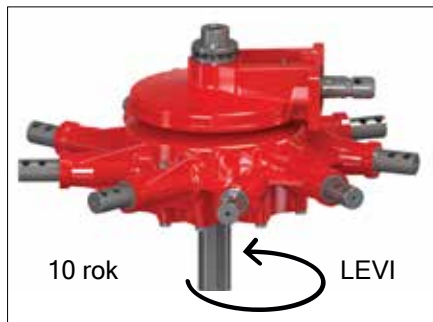

ŠIFRA ZA NAROČILO	št. rok	Z1	Z2	i	OBRATI/ min	TEŽA kg	OPIS
215014001	10	10	82	8,2:1	540	120	za zgrabljalnik dvorotorski DESNI C-OT 654
215015001	10	10	82	8,2:1	540	120	za zgrabljalnik dvorotorski LEVI C-OT 654

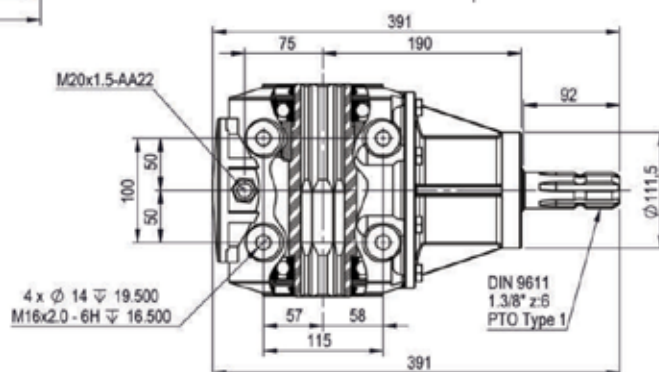
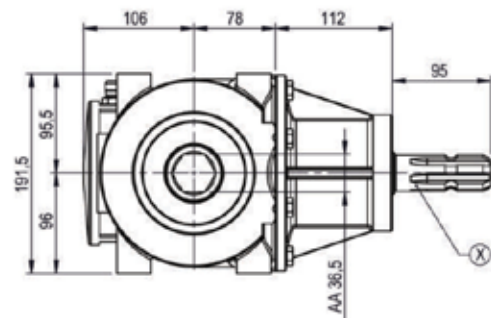
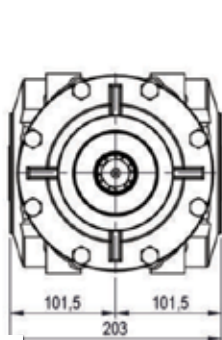
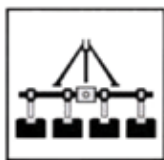

ŠIFRA ZA NAROČILO	PREMER GREDI AA	Z1	Z2	i	KW	KM	OBRATI/min	TEŽA kg	OPIS
198112	AA41	15	24	1,6:1	36,8	50	540	25	Okopalnik medvrstni

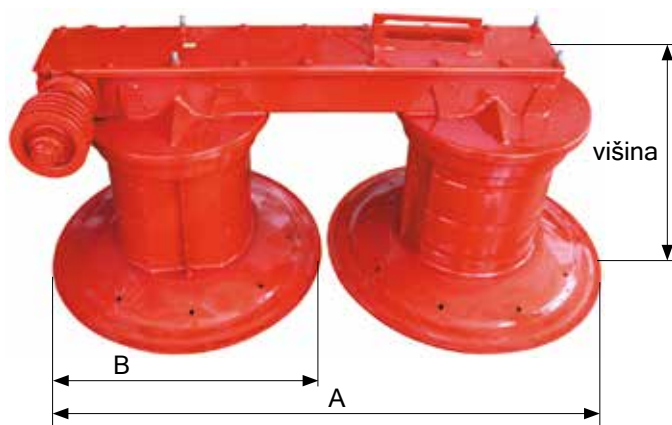

ŠIFRA ZA NAROČILO	št.nožev	A	B	VIŠINA	TEŽA kg	OPIS
180076	6	1286	628	573	176	kosilni greben komplet za ROTO135, RK135
176998	6	1571	768	573	206	kosilni greben komplet za ROTO165, RK16, PÖTTINGER ECONOMY 170





www.kptrgovina.si

HMEZAD KMETIJSKA PRESKRBA ŽALEC Šlandrov trg 19, 3310 Žalec, Slovenija

E-mail: trgovina.zalec@siol.net GSM: 041-232579 Tel: 03-5716758